

Condensate Filtration

KCF Series**Convenient and clean**

The Kaeser Condensate Filter (KCF) offers a convenient, economical and reliable method of condensate treatment. With today's stringent environmental guidelines, treating air compressor condensate is extremely important.

Condensate is a by-product of all compressors. This mixture of oil and water with ambient particulates and hydrocarbons is concentrated during the compression process. It is often classified as hazardous waste. Federal and local environmental laws often prohibit discharging untreated compressor condensate into surface drains.

Easy condensate filtration

Collecting and storing large volumes of contaminated condensate requires disposal by a waste collection service and can be very expensive. The KCF filters the oil from the water. The water can then be safely discharged into a drain. The KCF cartridge is designed to last 4-6 months depending on the type of compressor, type of lubricant, and ambient conditions. Each cartridge is supplied with a bag for easy disposal.

The KCF is easy to install and easy to maintain. Simply connect the unit to the condensate lines and it is ready to work. Multiple lines can be connected to

The KCF Advantage

- Works with most compressor fluids and lubricants*
- Simple, reliable operation
- Quick and clean filter cartridge change-out
- Single point connection
- No electricity required
- Connect multiple units for larger flows

*Check with Kaeser's Project Support department for compatibility

a single KCF using an optional manifold.

Two sizes are available to fit most applications. For larger flow requirements, simply connect multiple units using an optional flow splitter.



Operation

The condensate is fed under pressure into the inlet (1) and then into the pressure relief chamber (2) where the condensate is allowed to separate from the air. The settled condensate then flows into the cartridge where the oil is captured by a three-stage filtration process. The treated water then flows out the discharge pipe (3).

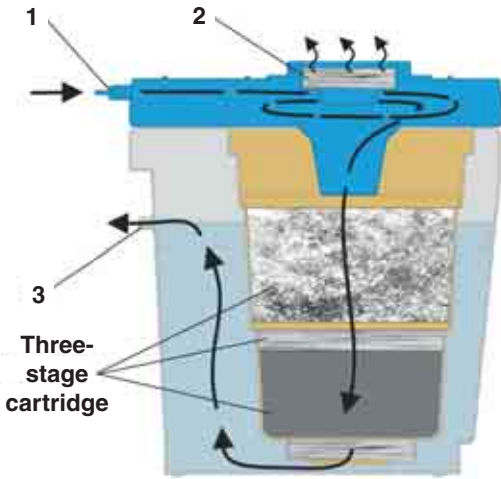

Specifications

Model	Capacity		Dimensions L x W x H (in.)	Dry Weight (lbs.)	Options
	Flow (cfm)	Compressor (hp)			
KCF 20	100	20	8 x 8 x 21	10	Flow Splitter / Manifold
KCF 100	500	18 x 21 x 24	25	Flow Splitter / Manifold	

Flow rates are based on 70°F and 70% relative humidity and may vary depending on compressor type, lubricant type, and ambient conditions. For best results use no air loss drains.
Specifications are subject to change without notice.

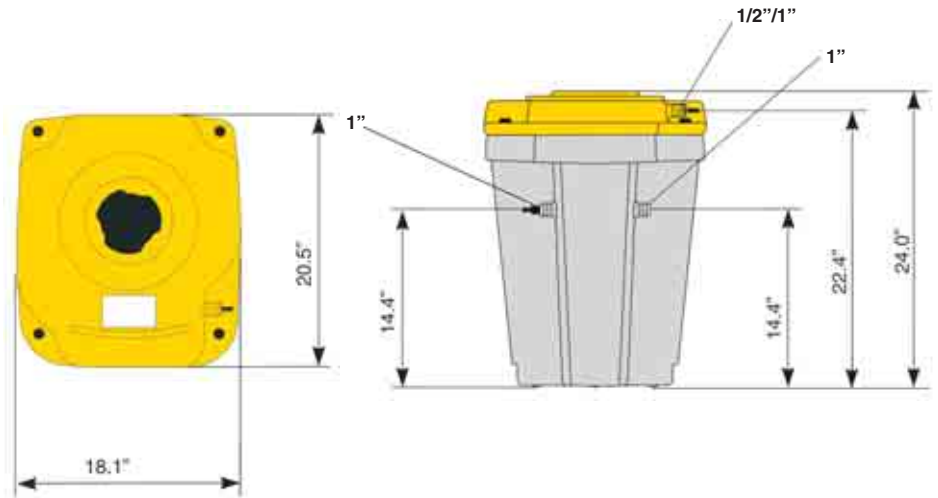

Disposing of compressed air condensate is a major environmental concern. This oil/water mixture is classified as hazardous waste and cannot be discharged into municipal wastewater systems unless the oil and contaminants are removed. The Kaeser Condensate Filter (KCF) is designed to filter out oil and other contaminants making the water safe for disposal. The key to the KCF function is the three-stage, self-contained plastic filter cartridge, which is extremely convenient for replacement and disposal. Check local regulations for proper disposal method.

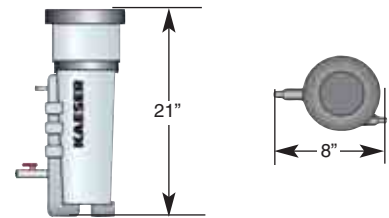

KAESER COMPRESSORS

Built for a lifetime.™

Corporate Headquarters:
P.O. Box 946
Fredericksburg, Virginia 22404
Phone 540-898-5500
Fax 540-898-5520
www.kaeser.com

Certified Management Systems



The Air Systems Specialist

With over 85 years of experience, Kaeser is the air systems specialist. Our extensive 100,000 square foot facility allows us to provide unequalled product availability. With service centers nationwide and our 24-hour emergency parts guarantee, Kaeser customers can rely on the best after-sales support in the industry. Kaeser stands committed to providing the highest quality air system for your specific compressed air needs.