

BSD Series

FAD from 3.6 to 8.15 m³/min
Pressures 5.5 to 15 bar



What do you expect from a compressed air system?

As a compressed air user, you expect maximum efficiency and reliability from your air system.

This sounds simple, but these advantages are influenced by many different factors: energy costs, for example, taken over the lifetime of a compressor, add up to a multiple of investment costs.

Efficient energy consumption therefore plays a vital role in the production of compressed air, as does reliability of the compressor.

In many cases, a reliable compressed air supply is essential to guarantee maximum performance from valuable production systems.

Reliability also ensures a supply of constant quality compressed air that optimises efficiency of the air treatment equipment downstream of the compressor.

With regards to noise protection, it is always better to keep noise emissions to a minimum from the outset by using a quiet compressor rather than have to retro-fit sound protection measures later on.

Last but not least, a truly efficient compressor is simple to maintain.

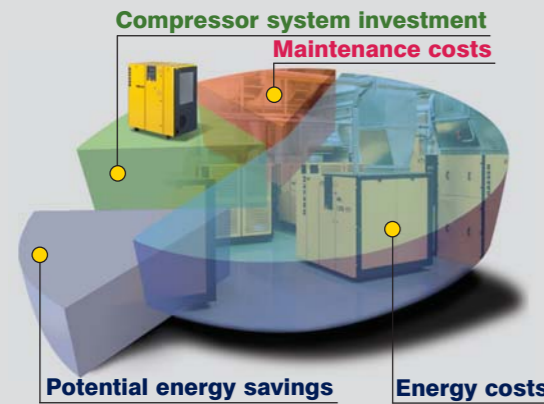

BSD – Quieter than quiet and highly efficient

KAESER's Solution: The BSD Series

The new BSD rotary screw compressors fulfil every customer requirement: they are highly energy efficient, quieter than quiet, require minimal maintenance, are extremely reliable and deliver the very best in air quality.

All of these advantages are aided through innovations in compressor design, drive systems, cooling and ventilation, silencing and maintenance methods.

In summary, the new BSD series of rotary screw compressors is a meticulously engineered and reliable product range built to KAESER's renowned high quality standards.



Savings through logical design

Direct intake ...

- ... of ambient air for cooling avoids pre-warming and ensures excellent cooling. The difference between compressed air outlet and ambient temperature is only 5 K, which reduces the energy requirement of downstream air drying equipment.
- ... of drive motor cooling-air from the surroundings ensures reliable and effective motor cooling even under adverse conditions.
- ... of air for compression from outside the compressor cabinet improves compression efficiency, the position of the inlet opening prevents pre-warming.

Three steps to greater efficiency:

1. Energy Saving SIGMA Profile



KAESER's SIGMA Profile airends save up to 15% energy compared with conventional screw compressor profiles. The airends in BSD units use even further refined rotors.

2. One-to-one drive



Some people talk of direct drive, but really mean geared drive. Make sure you know the difference. Maintenance costs and transmission losses are virtually eliminated, as the motor and airend on BSD units are connected via a simple coupling. Compared with compressors using small, high speed

gear-driven airends, one-to-one provides optimum use of power.

3. Powerful Radial Fan



The quiet and powerful radial fan draws in cool ambient air through the cooler. Its high residual thrust can deal with partial clogging of the cooler and still have enough reserve to allow connection of a long exhaust duct. In addition, the radial fan consumes significantly less drive power than conventional axial fans, saving even more energy.

One-to-one drive - ultimate efficiency

The BSD series is a range of compressors where the drive motor and the airend are designed to operate at the same low speed. The low speed operation is enabled with generously sized airends that are highly efficient and matched to the individual performances and pressures required. Significantly increasing reliability and service life, 1:1 drive reduces the number of components needed in comparison with gear drive and eliminates the associated transmission losses. Sound levels are also considerably lower. The benefits speak for themselves: Efficient power transmission, optimal energy consumption and reduced servicing / downtime costs.



Quieter than quiet

The quiet radial fan and directly coupled motor reduce noise at source. The real technical advance is in the combination of these components with the new cooling system. The separate air flow paths allow almost hermetic silencing without influencing cooling efficiency. With a sound power level of no more than 67 dB(A), the BSD series is approximately 10 dB (A) quieter than a comparable compressor. This is equivalent to a 90 percent noise reduction. Normal conversation can take place right next to the running compressor.

More air, more savings...



The rated motor powers given in the technical specifications below are reference points for selection of a suitable BSD Series compressor system.

Please contact KAESER for specific FAD and motor output data relating to other working pressures.

BSD Series - Technical Specifications

Model	Working pressure	FAD*) overall package at working pressure	Max. working pressure	Sound level**)	Rated motor power	Dimensions	Weight
	bar	m ³ /min	bar	dB(A)	kW	W x D x H	kg
BSD 62	7.5	5.65	8	68	30	1530 × 1005 × 1700	965
	10	4.45	11				
	13	3.60	15				
BSD 72	7.5	7.00	8	68	37	1530 × 1005 × 1700	1015
	10	5.60	11				
	13	4.40	15				
BSD 81	7.5	8.15	8	70	45	1530 × 1005 × 1700	1000
	10	6.80	11				
	13	5.43	15				

* FAD to ISO 1217: 1996, Annex C; **) Sound level to PN8NTC 2.3 at 1m distance, free-field measurement

BSD – Eight Decisive Advantages



1 SIGMA PROFILE air end

A given drive power can be used to turn a small air end at high speed or a larger air end at low speed. Larger, low speed air ends are more efficient, delivering more compressed air for the same drive power. That is why KAESER developed air ends especially for the BSD series that precisely match the individual drive power and motor speed of each machine in the range. The slightly higher cost of the larger air end is quickly recovered by the energy saved during operation.

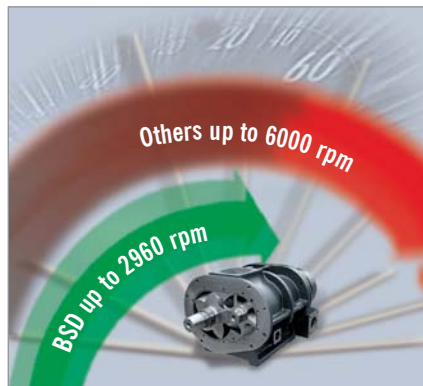

2 Energy-saving one-to-one drive

The advantage of this drive is not just the elimination of transmission losses. The motor and air end are joined by the coupling and its housing to form a compact and durable unit that, apart from greasing of the motor bearings, requires no regular maintenance. Should the coupling ever need to be replaced it takes just a few minutes without any disassembly of the unit. The opening in the housing is more than large enough to replace the two coupling sections.



3 Innovative radial fan

Quiet and efficient – the most important features of a radial fan. Low peripheral speed means low noise. Power consumption is up to 50 percent lower than a comparable axial fan. Another advantage is the high residual thrust (stable curve) that allows the use of exhaust ducting with a pressure drop of up to 60 Pa without the need for an additional extractor fan.

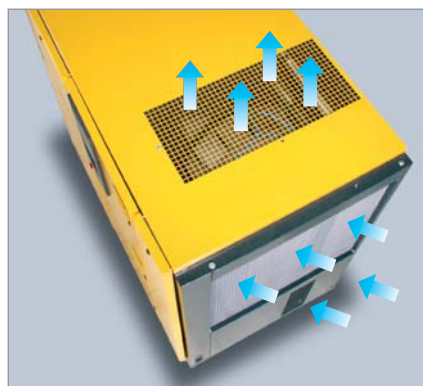

4 Efficient cooling system

In addition to improved cooling efficiency, the system has other benefits to offer. The inside of the cabinet remains clean because surrounding air is drawn through the cooler into the cooler box and then exhausted directly upward out of the machine. Dirt particles in the cooling air collect mainly on the air intake side of the cooler, on BSD units that means outside the cabinet. Clogging is easily noticed and quickly cleaned off without the need for any dismantling work. Operational reliability is improved and maintenance work significantly reduced.

5 Optimised oil separation system

BSD machines are fitted with a new, even more efficient separator system. The cooling fluid is initially separated from the compressed air by centrifugal force in the separator tank. Only a minimal amount of fluid remains to be removed by the high capacity, deep-bed filter in the separator cartridge. These two factors double the operational life of the cartridge compared with conventional systems and ensure minimum aerosol content in the compressed air delivery ($< 1 \text{ mg/m}^3$). The improved air quality eases the burden on the downstream air treatment components. The optional filter pressure drop monitoring set further enhances efficient operation.



6 Tailored cooling fluids and special fluid filters

KAESER units are filled as standard with the well proven SIGMA FLUID MOL coolant. However, upon request this can be substituted with synthetic SIGMA FLUID which is particularly suitable for intensively used equipment, as it allows an extended service interval of over 6000 operating hours. However, as a preventative protection measure for your equipment, we strongly recommend that a fluid analysis be carried out after 6000 operating hours due to the varied nature of environmental and intake conditions. A specially developed glass fibre fluid filter with enhanced contamination absorption capability is able to clean the cooling fluid more effectively, which is why the maintenance service interval has been able to be significantly increased. As a consequence, the special fluid filter and the synthetic SIGMA FLUID coolant not only help reduce service costs but also increase reliability.



7 Easy maintenance

All models feature high quality, durable components that are positioned logically and contribute to the outstanding performance and reliability of these compressor packages. Component accessibility is made simple through wide opening doors, easy lift off panels and a sensible design that ensures unrivalled ease of maintenance. The rear and left side of BSD units can be positioned right next to a wall to maximise use of space.



8 SIGMA CONTROL

Based on robust PC architecture, the SIGMA CONTROL offers the possibility of Dual, Quadro, Vario and Continuous control. Clearly marked navigation and input keys on the user interface are used to move around within the menu options of the four line alpha-numeric display. The SIGMA Control automatically controls and monitors the compressor (and refrigeration dryer in 'T' versions). The Profibus interface enables exchange of data and operational parameters allowing the SIGMA Control to communicate with other air management systems such as the SIGMA Air Manager. Connection of a modem even allows maintenance and alarm messages to be sent via SMS to relevant service locations.



Equipment

Complete unit

Ready for operation, fully automatic, super-silenced, vibration-damped, all panels powder coated.

Sound insulation

Lined with washable plastic foam; maximum 67 dB (A) to PN8NTC 2.3 at one metre distance, free-field measurement.

Vibration damping

Double insulated antivibration mountings using rubber bonded metal elements.



Airend

Genuine KAESER rotary screw, single-stage airend with SIGMA PROFILE and cooling fluid injection.

Drive

Directly coupled, no gearing

Electric motor

High efficiency CEMEP EFF1 motors consume less power for greater output and are standard throughout the range of KAESER compressors. The motors are protected to IP55 and conform to insulation Class F for greater power reserve. Also available with PTC thermistor sensors for full motor protection.

Electrical components

Control cabinet to IP 54, containing automatic star-delta starter, motor overload protection, control transformer and volt-free contacts for ventilation control.

Fluid and air flow

Dry air intake filter with initial separation, pneumatic inlet and venting valves, fluid reservoir with three-stage separator system, pressure relief valve, minimum pressure/check valve, thermostatic valve and fluid microfilter, all fully piped using newly-developed elastic couplings.

Cooling

The standard version is air cooled; separate aluminium coolers for compressed air and fluid, radial fan driven by its own motor.

SIGMA CONTROL

Interfaces for data communication comprising RS 232 for a modem or printer, RS 485 for a slave compressor in base load sequencing mode and a Profibus DP interface for data networks. Prepared for Teleservice.



Ergonomic control panel

Red, yellow and green LEDs show the operational state of the machine at a glance. The panel also contains a four-line plain text display, touch keys with icons and a duty cycle indicator.



Prime functions

Fully automatic monitoring and regulation of airend discharge temperature, monitoring of motor current, direction of airend rotation, air filter, fluid filter and fluid separator cartridge, display of performance data, service intervals of primary components, operating hours, status data and event memory data. Selection of Dual, Quadro, Vario and Continuous control modes as required.

(For further information refer to SIGMA CONTROL/SIGMA CONTROL BASIC brochure P-780)

Comprehensive design know-how



Compressed air supply systems are often highly complex and can only be efficiently operated in the long term if careful planning is implemented during each stage of design, system expansion and modernisation. KESS (KAESER's Energy Saving Service) provides com-

prehensive analysis of your compressed air usage, enabling KAESER's experts to plan and design a system that is specially tailored to meet all of your compressed air requirements. The service combines tried and tested compressed air components, user advice and

services with cutting edge technology to ensure maximum efficiency - KAESER air systems typically operate at 95 percent load capacity or more. Every KAESER compressed air system illustrates KAESER's commitment to producing application-specific quality compressed

Dimensions:

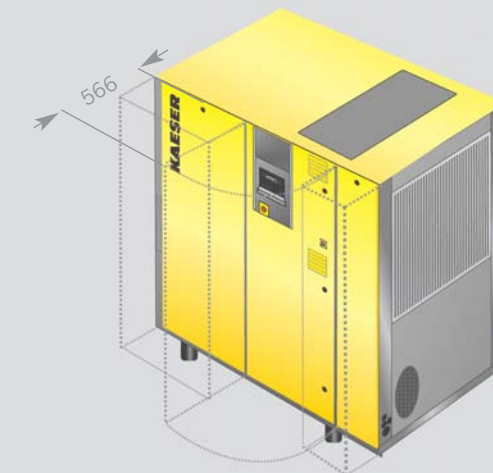

air at the lowest possible cost, combined with unsurpassed reliability. This standard is achieved with products of the highest quality and through decades of experience in design and construction of compressed air systems. Use this expertise to your advantage and let KAESER design your compressed air system.

Different fields of application need different grades of air treatment

Choose the required grade of treatment according to your field of application:

Air treatment using a refrigeration dryer (+3 °C pressure dew point)

Examples: selection of treatment classes to ISO 8573-1

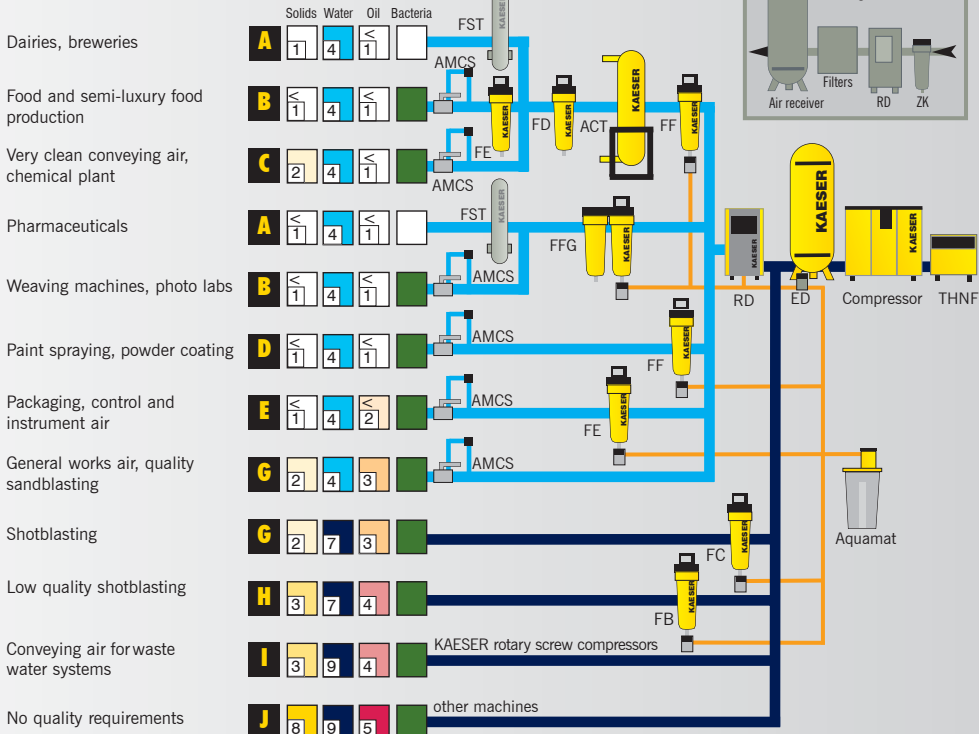

Explanation:

- THNF = bag filter**
cleans dusty and highly contaminated intake air
- ZK = centrifugal separator**
removes condensate
- ED = ECO Drain**
electronic level-controlled condensate drain
- FB = prefilter 3 µm**
separates liquid droplets and solid particles > 3 µm, oil content ≤ 5 mg/m³
- FC = prefilter 1 µm**
separates oil droplets and solid particles > 1 µm, oil content ≤ 1 mg/m³
- FD = particulate filter 1 µm**
separates dust particles (attrition) > 1 µm
- FE = microfilter 0.01 ppm**
separates aerosol oils and solid particles > 0.01 µm, aerosol content ≤ 0.01 mg/m³
- FF = microfilter 0.001 ppm**
separates aerosol oils and solid particles > 0.01 µm, oil content ≤ 0.001 mg/m³
- FG = activated carbon filter**
for adsorption of oil vapours, oil vapour content ≤ 0.003 mg/m³
- FFG = combination filter**
comprising FF and FG
- RD = refrigeration dryer**
pressure dew point to +3 °C
- DD = desiccant dryer**
for compressed air drying; DC series - heatless regeneration, pressure dew point to -70 °C; DW, DN, DTL and DTW series - heat regeneration, pressure dew point to -40 °C
- ACT = activated carbon adsorbent**
for adsorption of oil vapours, oil vapour content ≤ 0.003 mg/m³
- FST = sterile filter**
for bacteria-free air
- Aquamat = condensate treatment system**
- AMCS = air-main charging system**

For air mains subject to sub-zero temperatures: treatment systems with desiccant dryers (pressure dew point to -70 °C)

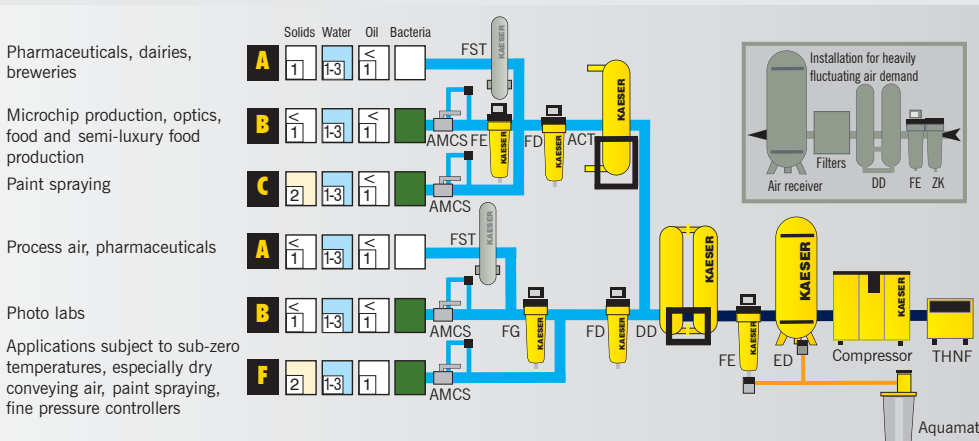

Contaminants:

+	solids	-
+	water	-
+	oil	-
+	bacteria	-

Degree of filtration:

ISO 8573-1 Class	Solid particles				Humidity Pressure dew point (x=liquid water in mg/m ³)	Oil concentration mg/m ³
	Max. no. of particles per m ³ with size d (µm)	as specified by user				
0	≤ 0.1	≤ 0.1	≤ 0.1	≤ 0.1	≤ -70 °C	≤ 0.01
1	100	1	0	-	≤ -40 °C	≤ 0.1
2	10000	1000	10	-	≤ -20 °C	≤ 1.0
3	-	-	500	-	≤ +3 °C	≤ 5.0
4	-	-	1000	-	≤ +7 °C	-
5	-	-	20000	-	≤ +10 °C	-
6	-	-	≤ 5	≤ 5	x ≤ 0.5	-
7	-	-	≤ 40	≤ 10	0.5 < x ≤ 5.0	-
8	-	-	-	-	5.0 < x ≤ 10.0	-

- A** Oil vapour content ≤ 0.003 mg/m³, particle retention > 0.01 µm sterile, odourless and taste-free
- B** Oil vapour content ≤ 0.003 mg/m³, particle retention > 0.01 µm
- C** Oil vapour content ≤ 0.003 mg/m³, particle retention > 1 µm

- D** Aerosol oil ≤ 0.001 mg/m³, particle retention > 0.01 µm
- E** Aerosol oil ≤ 0.01 mg/m³, particle retention > 0.01 µm
- F** Aerosol oil ≤ 0.01 mg/m³, particle retention > 1 µm
- G** Aerosol oil ≤ 1 mg/m³, particle retention > 1 µm

- H** Aerosol oil ≤ 5 mg/m³, particle retention > 3 µm
- I** Aerosol oil ≤ 5 mg/m³, particle retention > 1 µm
- J** Untreated