

ESD SFC Series

FADs from 5.0 to 40.5 m³/min
Pressures from 5.5 to 15 bar



What qualities do users look for in a compressor?

Normally, the answer would be efficiency and reliability. That may sound simple, but a lot of very different factors play an important part.

Energy costs, for example, taken over the lifetime of a compressor, add up to a multiple of investment costs.

This is why efficiency is vital in the production of compressed air.

Another major factor is the reliability of air supplies in the quality and quantity needed. This is the most significant requirement for production plant that relies on compressed air.

The quality that users look for in compressors with **variable frequency** drive is their ability to work together with one or more fixed speed compressors to form a combination that perfectly matches air supply to demand without wasteful unloaded running times and sequencing control gaps. Only with profound design knowledge and a comprehensive range of machines to choose from can combinations be chosen that realise their energy efficiency potential, bringing savings of up to 50 percent!

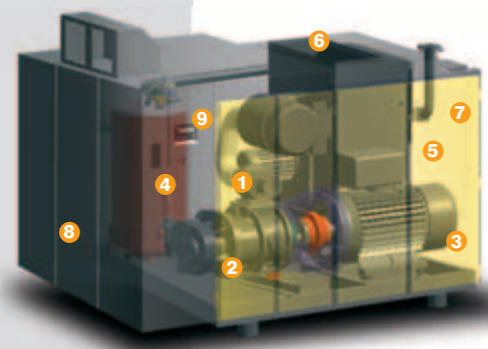
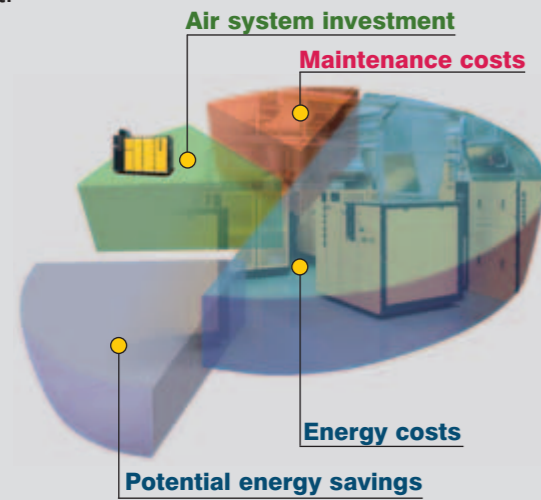

- 1 Inlet valve
- 2 Airend
- 3 High efficiency electric motor
- 4 Fluid separator/separator cartridge
- 5 Fluid cooler
- 6 Fluid filter
- 7 Air cooler
- 8 Control cabinet
- 9 SIGMA CONTROL

ESD SFC – ultimate efficiency

KAESER has the answer – the ESD SFC series

The new ESD SFC rotary screw compressors are a consequent reaction to customers' needs - economical power consumption, low noise emission, low maintenance effort, maximum reliability and even better air quality.

Major innovative solutions were introduced during the design of the drive system involving the overall cooling system, soundproofing and the reduction of servicing requirements.

This comprehensive series of compressors allows the introduction of a perfectly matched variable frequency package into a sequenced system to achieve targeted energy savings of up to 50 percent.



Short communication paths

The SFC cabinet and the ESD compressor form a compact unit. This reduces the footprint and ensures short communication paths between the control electronics and the drive motor. There's no need for any external wiring.



Zero noise interference

It goes without saying that the electromagnetic compatibility (EMC) of the components used and of the complete package is tested and certified to applicable directives.

Consequent energy-savers

Kaeser's ESD SFC series (SFC stands for SIGMA FREQUENCY CONTROL) are highly efficient rotary screw compressors with variable frequency drive. The performance of the large, low speed airends with the energy-saving SIGMA PROFILE is outstanding. Over the whole of the control range this performance is far superior to that of smaller airends trying to achieve the same delivery at higher speeds.

Score 3:0 for 1:1

1:1 drive completely eliminates transmission losses unavoidable in geared drive. It has fewer components, increasing reliability and service life. Noise emitted from the package is reduced. Compared with compressors using small, high speed, gear-driven airends, 1:1 drive gives you triple savings:

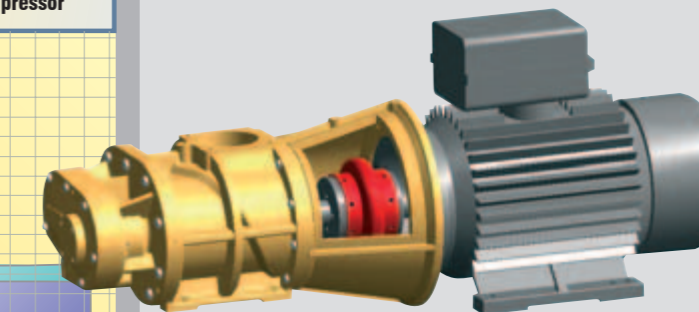
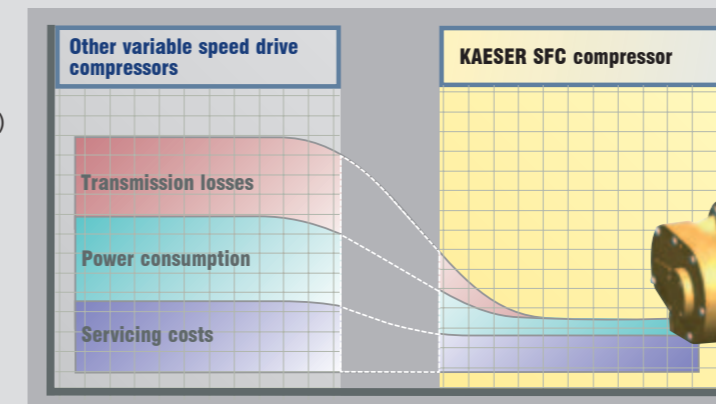

firstly with efficient power transmission, **secondly** with improved power consumption and **thirdly** with lowered servicing and related downtime costs.

Analysis reveals potential

ADA – Air Demand Analysis

To provide accurate data for optimisation of compressed air systems, KAESER has developed

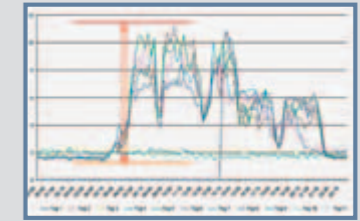

ADA, a computer-aided system for 'Air Demand Analysis'. **KESS**, the KAESER Energy Saving System, then finds the best solution for every

application using the profiles of air consumption calculated from ADA data.

KESS

KESS makes possible the design of a modern air supply system tailored to the user's application by processing the data logged by ADA and offering up a number of possible solutions. The most efficient solution

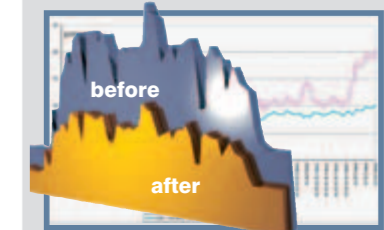

is selected by comparing the operating costs of each.

Your tailored solution

Based on the ADA profile of air demand and the KESS evaluation, KAESER engineers decide in

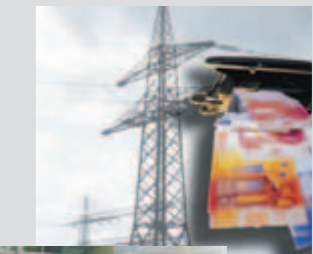

each case as to whether a combination of fixed speed and variable frequency compressors or a splitting concept using only fixed speed compressors is

preferable. Let KAESER tailor your air supplies to suit your facility. Our wide range of SFC machines ensures that the most economical solution can be found for every need.

SIGMA FREQUENCY CONTROL



Please refer to KAESER for specific capacities and motor powers for other working pressures.

ESD SFC series – technical specifications

Model	Max working pressure bar (g)	Free air delivery* at max working pressure m ³ /min	Max working pressure bar (g)	Speed range min - max rpm	Rated motor power kW	Dimensions W x D x H mm	Sound level** dB (A)	Weight kg
	7.5	8.45 – 33.0	6- 8.5	450 - 1650				5800
ESD 351 SFC	10	6.45 – 27.3	9-12	450 - 1710	200	3285×2142×2625	76	5800
	13	5.17 – 23.7	13-15	450 - 1800				5800
	7.5	10.2 – 40.5	6- 8.5	450 - 1725				6200
ESD 441 SFC	10	8.5 – 36.4	9-12	450 - 1845	250	3285×2142×2625	79	6200
	13	6.13 – 29.5	13-15	450 - 1920				6200

*) Capacity to ISO 1217: 1996, Annex C; **) Sound level to PN8NTC2.3 at 1m distance, free-field measurement

ESD SFC – eight decisive advantages

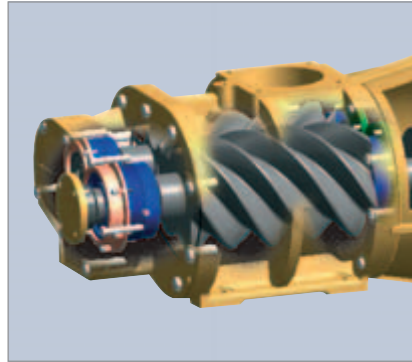

1 The airend with the SIGMA PROFILE

A certain drive power can be transferred with a small airend at high speed or with a large airend at low speed. Large, low speed airends are more efficient because they supply more air for the same drive power. This is why KAESER stopped counting the cost and developed a series of airends for the ESD packages of sizes that precisely match the individual drive power at low drive speeds. The investment in large airends is quickly returned because of the energy savings made during operation.

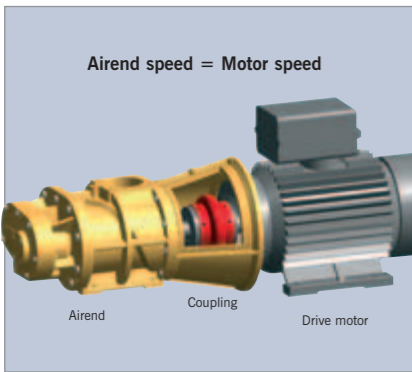

2 The energy-saving one-to-one drive

The advantage of this drive is not just the elimination of transmission losses. The coupling and its housing join the drive motor and the airend, creating a compact, durable unit that needs no regular maintenance except for greasing the motor bearings. Should the coupling ever need to be replaced it can be done without any disassembly in just a few minutes. The opening in the coupling housing is large enough to replace the two coupling sections.

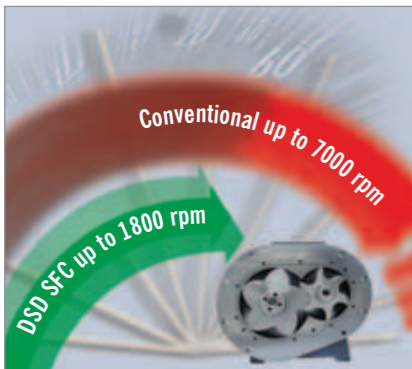

3 Low speed

ESD SFC compressor use standard KAESER mechanical components. This not only ensures highest reliability but guarantees optimum energy efficiency as well. Low speeds and the largest airend possible are the basic requirements for economical production of compressed air (the maximum speed of an ESD SFC is approximately 1890 rpm). Added to these features are long life, lower servicing needs and the use of standard drive motors, which contribute toward long-term reliability.



4 SIGMA CONTROL

SIGMA CONTROL is based on a robust industrial computer with a real time operating system and software update capability. The operational state of the compressor is easily recognised with the help of LEDs. A four-line, plain text display and easily understood icons and touch keys allow rapid set-up and operation of the controller. SIGMA CONTROL automatically regulates and monitors the compressor and SFC module and if an alarm occurs shuts them down immediately. Interfaces for connection of a modem or printer, a second compressor working in sequence and a data network (Profibus DP) are provided.

5 SIEMENS frequency inverter

For very good reasons only frequency inverters from Siemens are used for KAESER's variable speed compressors: inverter efficiency is the maximum possible; there is maximum compatibility between the SFC control cabinet and SIGMA CONTROL; the compressor controller itself is based on a SIEMENS industrial computer; global service is guaranteed at all times because of the worldwide presence of SIEMENS, and finally, the SFC control cabinet and SIGMA CONTROL are tested and certified both as individual components and as a system to EMC directives EN 55011 class A, group 1 for industrial mains networks.



6 Precise pressure control

The air generated by an ESD SFC compressor can be matched to the actual system requirement over the range of control by continuously varying the speed of the drive motor and airend depending on pressure. During this process it is possible to keep system pressure within narrow limits of ± 0.1 bar independent of the buffer capacity of the air main volume. Reducing maximum pressure eliminates wasteful power consumption; a reduction of only one bar lowers energy consumption by seven percent. A correctly designed SFC machine can be sequenced with standard rotary screw compressors without problem.

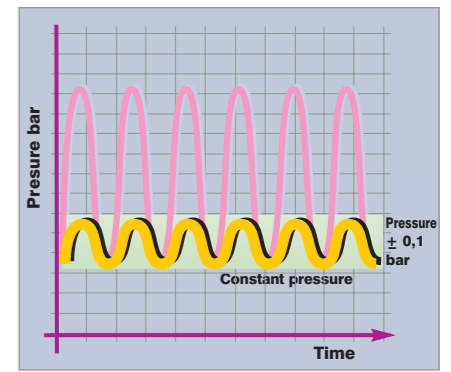

7 Flexible pressure

The wide range of available directly-coupled rotary screw airends produced by KAESER make it possible to use the one that works most efficiently within the range of pressure and delivery required. The right choice of airend results in the most economical pressure-to-frequency profile for the ESD SFC machines. A pressure-to-frequency band profile that ensures maximum flexibility both in pressure and volume under the aspect of highest possible economy is programmed into the SIGMA CONTROL (pressure ranges: 6-8.5 bar, 9-12 bar and 13-15 bar).

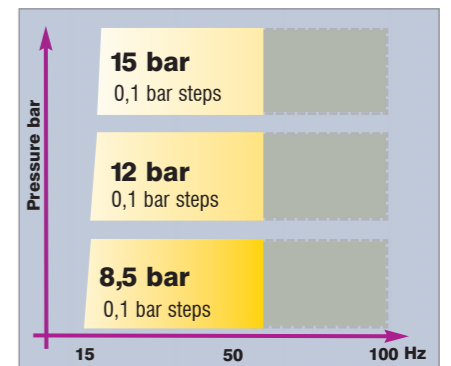

8 Low specific energy requirement

Large, low speed airends are more efficient. They deliver more compressed air for the same drive power, not just at full load but over the whole range of control – an important aspect as far as variable frequency controlled machines are concerned. The specific energy requirement* of KAESER SFC compressors of 6.12 kW per m³/min at 7.5 bar can be considered as an excellent indication of the machine's efficiency. Variable frequency controlled compressors are only efficient if their specific energy requirement is a minimum over the whole of their range of control.

*effective electrical energy consumption / FAD = specific energy requirement



Equipment

Overall package

Ready for operation, fully automatic, super-silent, vibration damping, all panels powder coated

Sound damping

Plastic foam with washable surface; maximum 79 dB(A) to PN8NTC at one metre distance, free-field measurement

Vibration damping

Dual anti-vibration mountings using rubber bonded metal elements

Airend

Genuine KAESER rotary screw, single-stage airend with the SIGMA PROFILE and cooling fluid injection



Drive

Direct, torsion-elastic coupling, without gearing

Electric motor

Industry standard, high-efficiency electric motor of quality German manufacture to IP 55 and insulation class F for additional reserve, PTC thermistor sensor (full motor protection)

Joint between electric motor and airend

Airend with integrated coupling flange



Electrical components

Control cabinet to IP 54; control transformer; SIEMENS Masterdrive with control panel;

volt-free contacts for ventilation systems

Air flow

Air intake filter with initial separation; pneumatic inlet and venting valves; pressure relief valve, minimum pressure/check valve; rigid piping with flexible couplings used for fluid/air line; air-cooled combination cooler made of aluminium for fluid and compressed air; radial fan with separate electric motor

Cooling fluid circulation

Cooling fluid reservoir with three-stage separator system; thermostatic valve and fluid filter; charged with SIGMA FLUID PLUS cooling fluid



SIGMA CONTROL

Interfaces: RS 232 for modem or printer, RS 485 for a slave compressor in base load sequence mode and Profibus DP for data networks; prepared for Teleservice

Ergonomic control panel

Red, yellow and green LED's (traffic light functions) show the operational state of the compressor. Four-line, plain text display; touch keys with LED icon indications; display of duty cycle.



Some important functions

Fully automatic monitoring and control of airend discharge temperature, motor current, direction of airend rotation, air filter, fluid filter and fluid separator element; display of performance data; hours counter for main components such as motor, etc, service hours, display of status data and event memory data.

(See SIGMA CONTROL brochure P-780 for more information)

Dimensions:

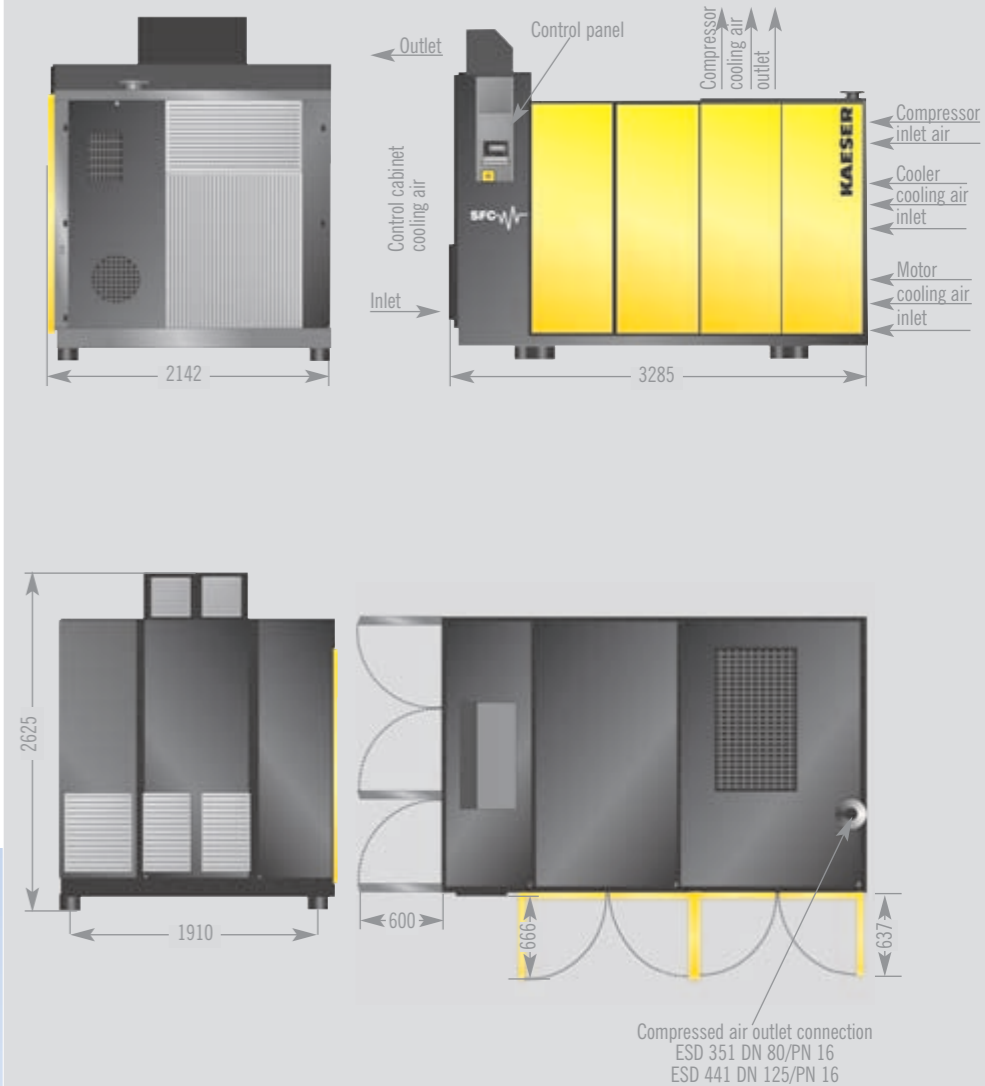

Comprehensive design knowledge



Depending on the application, compressed air systems are often highly complex. Over the long term, they can only be operated efficiently if this fact is adequately taken into account during design, extension,

modernisation and daily operation. KESS (KAESER Energy Saving Service) is available to you as a comprehensive service concept that determines the optimum means of supplying the compressed air needed for your factory.

This service combines elements such as air components, user advice and services that have proven themselves over years of practice with new ideas made possible by the optimised use of data processing in the compressed air field. Air systems planned and designed by KAESER are featured by their efficient

use of energy. Duty cycle factors for the compressors of 95 percent and more are possible. Air quality tailored to the application at lowest cost and high operational reliability is a further characteristic typical of a KAESER air

system. This high standard has been achieved through years of experience in system and plant design, computer-aided analysis and 3-D design aids.

Why not take advantage of this knowledge and have your air system designed by KAESER.

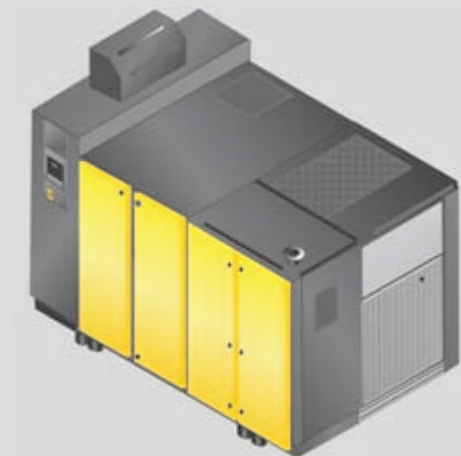

Choose the required grade of treatment according to your field or application: Air treatment using a refrigeration dryer (+3 °C pressure dew point)

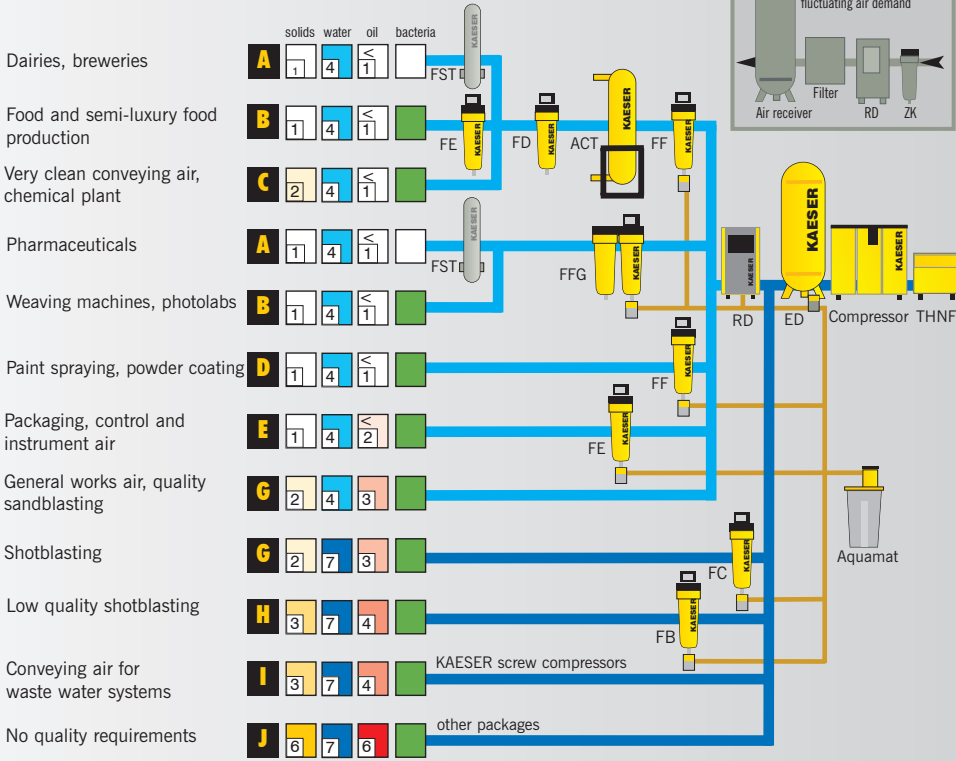

Explanation:

- THNF = bag filter**
cleans dusty and highly contaminated intake air
- ZK = centrifugal separator**
separates accumulating condensate
- ED = ECO DRAIN**
electronic level controlled condensate drain
- FB = prefilter 3 µm**
separates liquid droplets and solid particles >3 µm, oil content ≤5 mg/m³
- FC = prefilter 1 µm**
separates oil droplets and solid particles >1 µm, oil content ≤1 mg/m³
- FD = particulate filter 1 µm**
separates dust particles (attrition) >1 µm
- FE = microfilter 0.01 ppm**
separates oil aerosols and solid particles >0.01 µm, aerosol oil content ≤0.01 mg/m³
- FF = microfilter 0.001 ppm**
separates oil aerosols and solid particles >0.01 µm, aerosol oil content ≤0.001 mg/m³
- FG = activated carbon filter**
for adsorption of oil vapours, oil vapour content ≤0.003 mg/m³
- FFG = combination filter**
comprising FF and FG
- RD = refrigeration dryer**
dries compressed air, pressure dew point to +3 °C
- DD = desiccant dryer**
dries compressed air, DC series: heatless regeneration, pressure dew point to -70 °C
DW, DN, DTL, DTW series: heat regeneration, pressure dew point to -40 °C
- ACT = activated carbon adsorber**
for adsorption of oil vapours, oil vapour content ≤0.003 mg/m³
- FST = sterile filter**
provides bacteria-free compressed air
- Aquamat** = for condensate separation

Contaminants:

+	solids	-
+	water	-
+	oil	-
+	bacteria	-

Degree of filtration:

Class	Solid particles				Humidity		Total oil concentration mg/m ³
	Max. no. of particles per m ³	Particle size d (µm)			Pressure dewpoint	(x=concentration of liquid water in mg/m ³)	
1	100	0.1 < d ≤ 0.5	0.5 < d ≤ 1.0	10 < d ≤ 50	≤ -70 °C	≤ 0.01	
2	100000	1000	10	-	≤ -40 °C	≤ 0.1	
3	-	10000	500	-	≤ -20 °C	≤ 1.0	
4	-	-	1000	-	≤ +3 °C	≤ 5.0	
5	-	-	20000	-	≤ +7 °C	-	
6	-	-	-	≤ 5	≤ +10 °C	-	
7	-	-	-	≤ 40	x ≤ 0.5	-	
8	-	-	-	≤ 10	0.5 < x ≤ 5.0	-	
9	-	-	-	-	5.0 < x ≤ 10.0	-	

For air mains endangered by frost: treatment with a desiccant dryer (down to -70 °C pressure dew point)

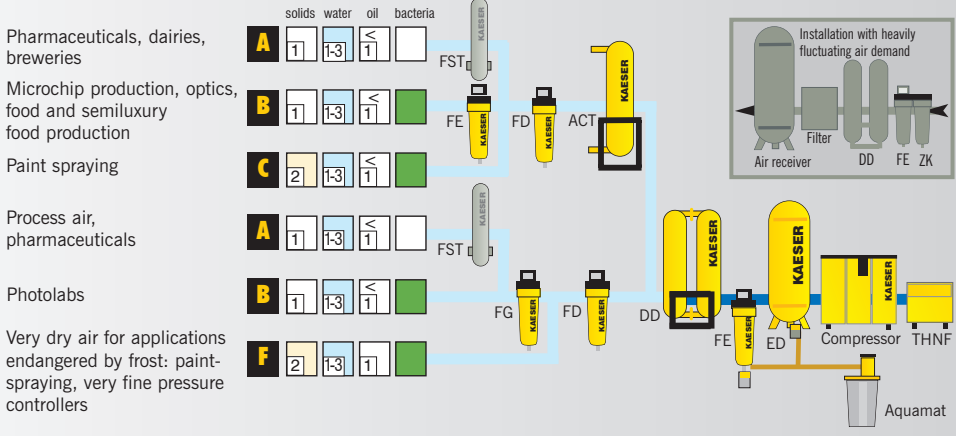

- A** Oil vapour content ≤ 0.003 mg/m³, particle retention > 0.01 µm, sterile, odourless and tasteless
- B** Oil vapour content ≤ 0.003 mg/m³, particle retention > 0.01 µm
- C** Oil vapour content ≤ 0.003 mg/m³, particle retention > 1 µm

- D** Aerosol oil ≤ 0.001 mg/m³, particle retention > 0.01 µm
- E** Aerosol oil ≤ 0.01 mg/m³, particle retention > 0.01 µm
- F** Aerosol oil ≤ 0.01 mg/m³, particle retention > 1 µm
- G** Aerosol oil ≤ 1 mg/m³, particle retention > 1 µm

- H** Aerosol oil ≤ 5 mg/m³, particle retention > 3 µm
- I** Aerosol oil ≤ 5 mg/m³, particle retention > 1 µm
- J** untreated