

## Compressed Air Dryers

**TX Series****Water is extremely harmful to compressed air systems!**

Hot compressed air contains a large amount of water. In fact, at 75°F and 75% relative humidity, a typical 25 hp compressor will generate 6 gallons of water every 8 hours.

As the saturated air moves downstream, water vapor cools and condenses into liquid. As a liquid, water promotes rust and corrosion in piping, tools and product. Rust leads to air leaks and pressure drops. Maintenance and repair costs on pneumatic equipment

increase, products can be ruined, and production time is lost.

Kaeser's TX Series refrigerated dryers efficiently remove the harmful moisture by cooling the air and forcing moisture to condense. Once condensed, the water is removed from the system by a separator and drain trap.

**Efficient design**

TX series dryers are built for maximum efficiency, durability, and reliability. Low pressure drops are achieved due to smooth tube copper heat exchangers.

**Capacity**

- 10 and 15 cfm @ 100 psig

**Instrumentation and Controls**

- Power cord with plug
- Power on light

*All dryers are UL 508 listed, CSA certified, and use environmentally friendly R134a refrigerant*

**Reliability**

Only carefully selected, high quality components are built into each dryer. The result is exceptional reliability. Advanced engineering has reduced the number of joints and components of the dryer thus lowering the potential for leaks and malfunctions.

**Value**

High efficiency features, high reliability, and easy maintenance make the TX refrigerant dryer an exceptional value.

# Operation

Warm saturated air enters the Evaporator (A) where it is cooled by the evaporating refrigerant. As the compressed air cools, water vapor condenses and is separated from the air stream by the Moisture Separator (B). The Automatic Condensate Drain (C) ejects the separated liquid from the system. The cold, dry air is reheated by hot refrigerant in the Air Reheater (D), preventing “sweating” of downstream piping, and exits the dryer.

The Static Condenser (E) radiates heat from the hot refrigerant being discharged by the Refrigerant Compressor (F). The partially cooled refrigerant then passes through the Air Reheater (D) where it is cooled further. The Constant Pressure Expansion Valve (G) meters the flow of cool, liquid refrigerant into the Evaporator (A) to maintain proper cooling under all load conditions. This assures a constant evaporator temperature and prevents freeze-up, assuring continuous and automatic dew point control.

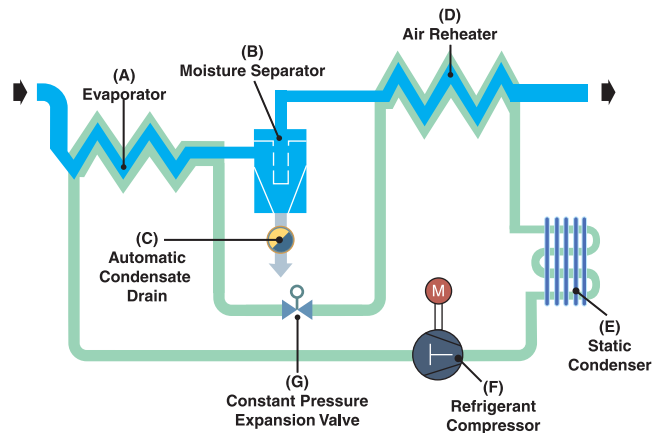

## Specifications

Model	Rated Capacity* (scfm)	Power Supply <sup>1</sup> (V / Ph / Hz)	Inlet/Outlet Connections <sup>2</sup> (in.)	Dimensions W x D x H (in.)	Weight (lbs.)
TX 2	10	115 / 1 / 60	3/8	13 x 13 x 15	42
TX 3	15				47

\*Rated capacity: Based on compressed air saturated at 100°F and 100 psig and operation in a 100°F ambient.

- Maximum inlet temperature: 130°F
- Maximum allowable working pressure: 250 psig
- Maximum/minimum ambient air temperature: 110/40°F

<sup>1</sup> 50 Hz also available    <sup>2</sup> Connection is copper tube and must be brazed

## Selecting the Proper Dryer

To correct Rated Capacity for actual operating conditions, refer to “Capacity Correction Factors for Operating Conditions” and “Capacity Correction Factors for Ambient Temperature”. Find the capacity correction factors corresponding to the inlet and ambient conditions. Multiply these factors to

find the “overall” capacity correction factor, then multiply any dryer’s rated capacity by the overall correction factor to determine its capacity at your operating conditions. Capacity correction factors for conditions not shown may be interpolated.

*Specifications are subject to change without notice.*

**Table 1: Capacity Correction Factors for Operating Conditions**

Inlet Pressure psig	Inlet Temperature (°F)			
	90	100	110	120
80	1.17	0.95	0.79	0.66
100	1.23	1.00	0.82	0.70
125	1.31	1.07	0.91	0.74
150	1.37	1.13	0.95	0.80
175	1.42	1.18	0.99	0.84
200	1.47	1.22	1.03	0.89
250	1.49	1.24	1.05	0.91

**Table 2: Capacity Correction Factors for Ambient Temperature**

Correction Factor	Ambient Air Temperature (°F)			
	80	90	100	110
	1.12	1.06	1.00	0.94

# KAESER COMPRESSORS

**Built for a lifetime.™**

[www.kaeser.com](http://www.kaeser.com)

**Kaeser Compressors, Inc.**  
511 Sigma Drive  
Fredericksburg, VA 22408 USA  
Telephone: 540-898-5500  
Toll Free: 800-777-7873  
info.usa@kaeser.com

**Kaeser Compressors Canada Inc.**  
3760 La Verendrye Street  
Boisbriand, QC J7H 1R5 CANADA  
Telephone: (450) 971-1414  
Toll free: (800) 477-1416  
info.canada@kaeser.com

**Kaeser Compresores de México S de RL de CV**  
Calle 2 #123  
Parque Industrial Jurídica  
76100 Querétaro, Qro.  
Telephone: 01 (442) 218 64 48  
sales.mexico@kaeser.com

**Kaeser Compresores de Guatemala y Cia. Ltda.**  
Calz. Atanasio Tzul 21-00, zona 12  
El Cortijo II, Bodega 501  
01012–Guatemala City  
Telephone: +502 2412-6000  
info.guatemala@kaeser.com

Certified Management Systems

