

## 165013 (MPV-625) AIR SUPPLIED RESPIRATOR

**IMPORTANT:** Read and follow this service literature before you use the respirator. The literature explains the proper use, care and safety precautions for your respirator. Keep for future reference.

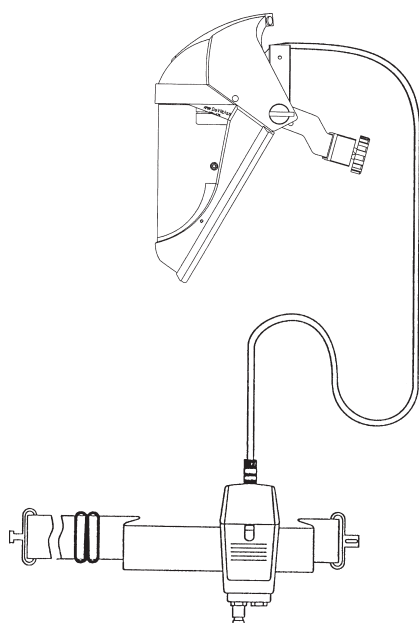

PERMISSIBLE  
Supplied Air Respirator  
Type C Continuous-Flow Class

### LIMITATIONS

Approved for respirator protection against atmospheres not immediately dangerous to life or health. Not for use in atmospheres containing less than 19.5 percent oxygen.



### WARNING

This respirator must not be worn in any atmosphere immediately dangerous to life or health.

Follow the manufacturer's instructions for providing a supply of respirable air.

In making renewals or repairs, parts identical with those furnished by the manufacturer under the pertinent approval shall be maintained.

This respirator shall be selected, fitted, used and maintained in accordance with The National Institute for Occupational Safety and Health, Occupational Safety and Health Administration and other applicable regulations.

### WARNING

Severe or long term illness can occur if the wrong type of respiratory protection is used. This respirator will only provide protection against certain kinds and limited amounts of materials. Never use this respirator for protection against:

- Asbestos containing dusts and mists
- Sandblasting
- Any material used in a closed or poorly ventilated area

A respirator must be properly prescribed and fitted to your needs. OSHA and industry standards require:

- A qualified safety expert or industrial hygienist select the correct respirator
- The correct respirator can only be selected after finding out the kinds and amounts of toxic materials to which you will be exposed.

### DESCRIPTION



### WARNING

Risk of illness or death. Follow all instructions. The activated carbon filter does not remove carbon monoxide or carbon dioxide.

This air supplied respirator is designed to provide a high level of protection in contaminated atmospheres when worn and used correctly. It is not for use in atmospheres immediately dangerous to life or health; and, if accidentally disconnected or removed, the wearer must be able to safely reach a clean, breathable air supply. The compressed air supply to the respirator must be of breathable quality (Grade D) and conform to 42 CFR 84.141 (a) (b) and relevant national standards.

This air supplied respirator has a light-weight, fully adjustable headband and browguard. The detachable acetate visor can be lifted up from the face when the operator is not working in a hazardous area. Two half turn tension knobs adjust the visor movement. Two disposable visor covers are provided.

The visor air feed tube is connected to a filter/regulator attached to the waist belt. The preset compressed air pressure regulator maintains a constant flow of air to the visor. See table on page 2 for approved hose length and pressure ranges. Operating inlet pressure range is 45 psi (3.1 bar) to 100 psi (6.8 bar) (see table on page 2). Nominal flow rate to the visor is 6.0 CFM (170 liters/min.). The disposable activated carbon filter removes odor, particulates and oil vapor and incorporates a color change indicator. The filter should be changed when odors are no longer effectively removed or when oil vapor activates the start of a color change from white to red. Appropriate filters should be fitted at the supply hose inlet to provide Grade D breathing air, such as a DeVilbiss breathable air panel.

A storage bag is supplied to keep the visor safe and clean when not in use.

**SAFETY PRECAUTIONS**

This manual contains information that is important for you to know and understand. This information relates to USER SAFETY and PREVENTING EQUIPMENT PROBLEMS. To help you recognize this information, we use the following symbols. Please pay particular attention to these sections.



**Important safety information - A hazard that may cause serious injury or loss of life.**



**Important information that tells how to prevent damage to equipment, or how to avoid a situation that may cause minor injury.**

**Note**

Information that you should pay special attention to.

**SPECIFICATIONS**

The 165013 (MPV-625) Air Supplied Respirator consists of:

165015 (MPV-480) Visor Assembly with ratchet headband, detachable visor covers, hair and neck cover, storage bag and quick detachable stem to attach flexible hose to 160014 (MPV-469) waistbelt.

160014 (MPV-469) Waistbelt Assembly: An adjustable nylon belt with quick fit buckle. The disposable carbon odor removal filter and preset regulator are contained in a molded housing which is moveable on the belt.

A DeVilbiss 160015 (MPV-530) or 160016 (MPV-550) Breathable Air Hose must be purchased separately and used in conjunction with the 165013 (MPV-625) respirator to properly operate the system and to maintain NIOSH approval.

**CAUTIONS AND LIMITATIONS**

Not for use in atmospheres containing less than 19.5 percent oxygen.

Not for use in atmospheres immediately dangerous to life or health.

Do not exceed maximum use concentrations established by regulatory standards.

Air line respirators can be used only when the respirators are supplied with respirable air meeting the requirements of CGA G-7.1 Grade D or higher quality.

Use only the pressure ranges and hose lengths specified in the instruction manual.

Do not use respirator if airflow is less than 4 cfm (115 lpm) for tight fitting face pieces or 6 cfm (170 lpm) for hoods and/or helmets.

Failure to properly use and maintain this product could result in injury or death.

All approved respirators shall be selected, fitted, used and maintained in accordance with MSHA, OSHA and other applicable regulations.

Never substitute, modify, add or omit parts. Use only exact replacement parts in the configuration as specified by the manufacturer.

Refer to users instructions, and/or maintenance manuals for information on use and maintenance of these respirators.

Special or critical user's instructions and/or specific use limitations apply. Refer to user's instructions before donning.

Hose approved for up to 100 ft. in total length.

**SPECIAL USER INSTRUCTIONS**

This respirator is approved for use with 30 to 100 ft. of air hose within the following pressure ranges:

Hose Size I.D. Inches	Hose Length Feet	Min. Press. One Hose Length PSI	Min. Press. Two Hose Lengths PSI	Max. Press. PSI
5/16	30	45	55	100
5/16	50	52	60	100

**INSTALLATION AND OPERATION**



**Risk of illness or death. Never use this respirator in an area where the atmosphere is immediately hazardous to life or health. In an emergency, the wearer must be able to escape from the work area without the need of a respirator.**

**The air supplied must be of breathable quality and confirm to 42 CFR 84.141 (a) (b) and the relevant national standards.**

The air intake of the compressor is especially vulnerable to all types of carbon monoxide sources. The air compressor air intake must be located in an area where the air being compressed is clean and free of airborne contaminants.

Breathable air source must be of a grade "D" level or higher. This consists of the following:

**Oxygen** = 19.5 to 23.5% (typical atmospheric levels)

**Oil (condensed)** = 5 mg/m (milligrams per cubic meter)

**Carbon monoxide** = 10 ppm (parts per million) max.

**Carbon dioxide** = 1000 ppm (parts per million) max.

**Odor** = The presence of a pronounced odor should render the air as unsatisfactory

Test the compressed air supply for the presence of carbon monoxide. This can be accomplished by the use of a Gas Detector Tube or Electronic Carbon Monoxide Monitor. The testing should be done immediately.

If carbon monoxide is found, the cause must be located and corrected before the worker can use the respirator from that air supply.



**Carbon monoxide can cause nausea, fainting or death. Stop using the air supply if carbon monoxide is present. A Carbon Monoxide Monitor does not remove carbon monoxide.**

Supply air must be filtered and regulated. See Table in column 2, page 3, for required air pressure for various hose lengths.

**Note**

It is required that a Devilbiss breathable air supply hose is used and specifically identified for breathing air, such as, as Devilbiss 160001 (MPV-530) or 160016 (MPV-550) breathable air hose. Each user should have their own visor assembly.

**Wearing Instructions**

**Risk of illness. Avoid breathing contaminated air. Read and follow the instructions below before entering a contaminated area.**

1. Connect the air supply hose to the outlet source of Grade D air. See illustration on page 6. Do not turn on the air supply.

**Note**

Ensure that the supply hose is long enough to allow the operator to enter and leave the contaminated area without disconnecting or removing the visor.

2. Check the waistbelt and respirator assemblies ensuring that all parts are in good condition. Replace if damaged.
3. Attach and adjust the waistbelt assembly ensuring that the supply air inlet is pointing down.
4. Connect the air supply hose to the waistbelt inlet.
5. Connect the respirator feed tube to the female quick disconnect on top of the filter assembly.
6. Place the browguard visor assembly on head; and with the visor in the open position, adjust the crown strap and tension knobs to obtain a secure fit. Ensure that the feed tube is not twisted or kinked and will not interfere with normal movements. Make sure the ears are not tucked inside the faceseal cassette. **Do not place ears inside faceseal cassette.**
7. Turn on the air supply and check that air is flowing freely to the inside of the visor.

8. Adjust the inlet air pressure to ensure that the supply pressure at the inlet of the supply hose is within the guidelines of the following table:

Hose Size I.D. Inches	Hose Length Feet	Min. Press. One Hose Length PSI	Min. Press. Two Hose Lengths PSI	Max. Press. PSI
5/16	30	45	55	100
5/16	50	52	60	100

9. Before entering the contaminated area, the visor must be pulled down so the fabric skirt is touching the face all the way around and the tension knobs are adjusted so the visor is locked in this position.



**Risk of diminished air flow. When adjusting air pressure to other units, ensure that the pressure to the waistbelt assembly at the point of attachment is maintained at a minimum of approved pressure.**

**MAINTENANCE**

**Inspection**

1. Inspect equipment before each use for damaged parts. Pay particular attention to the hose and visor feed tube — replace if there is any sign of abrasion, cuts, cracks, kinks, or distortion.
2. Replace visor covers as necessary to ensure clear vision. Do not spray paint or use chemicals without a protective visor cover 165018 (MPV-44) in place.
3. Check for air leaks whenever pressure is first applied. Check and make sure the hose connections are secure and that the hoses and fittings are in good condition. Replace if damaged.
4. Check before each use that the fabric skirt is free from tears, rips, distortion, dirt, contaminants, and discoloration and is properly fitted.
5. Check the waistbelt periodically for general wear.
6. Replace the activated carbon cartridge when the white indicator pad becomes pink or if any odors are experienced during wearing.

**Cleaning**

1. Regularly clean and/or disinfect the visor and headband assemblies. **DO NOT USE PAINT SOLVENTS.** Solvents will attack the plastic lens and render it unusable.

**Recommended solutions:**

- a. Cleaning: 1/2 teaspoon (3 ml) of liquid detergent to 1 quart (1 liter) of warm water, mix thoroughly.
- b. Disinfectant: 1/2 teaspoon (3 ml) of bleach to 1 quart (1 liter) of warm water, mix thoroughly.

**Method for cleaning and/or disinfecting:**

Use a lint free cloth dampened with the solution and wipe the inside and outside of the visor and headband assemblies. Repeat with a clean, lint free cloth dampened with clean, lukewarm water. Allow to dry naturally. Maximum ambient temperature 104° F. (40°C).

**REPLACEMENT OF PARTS**



**Use only DeVilbiss replacement components. Use of non-DeVilbiss parts may cause equipment malfunction and create an unsafe condition for the end user, as well as void the NIOSH approval.**

**To replace the activated carbon filter:**

1. Turn off air supply to the waistbelt and remove air supply hose.
2. Unscrew the two screws at the top of the waistbelt housing and one screw on the front.
3. Tilt the regulator forward to release the black locating lug from the slot in the front of the lower half of the waistbelt housing.
4. Remove the old carbon cartridge and fit a new replacement.
5. Relocate the black lug on the regulator into the slot on the lower half of the waistbelt housing.
6. Align regulator to bottom housing and tighten the three screws.
7. Replace air supply hose and check that there are no air leaks.

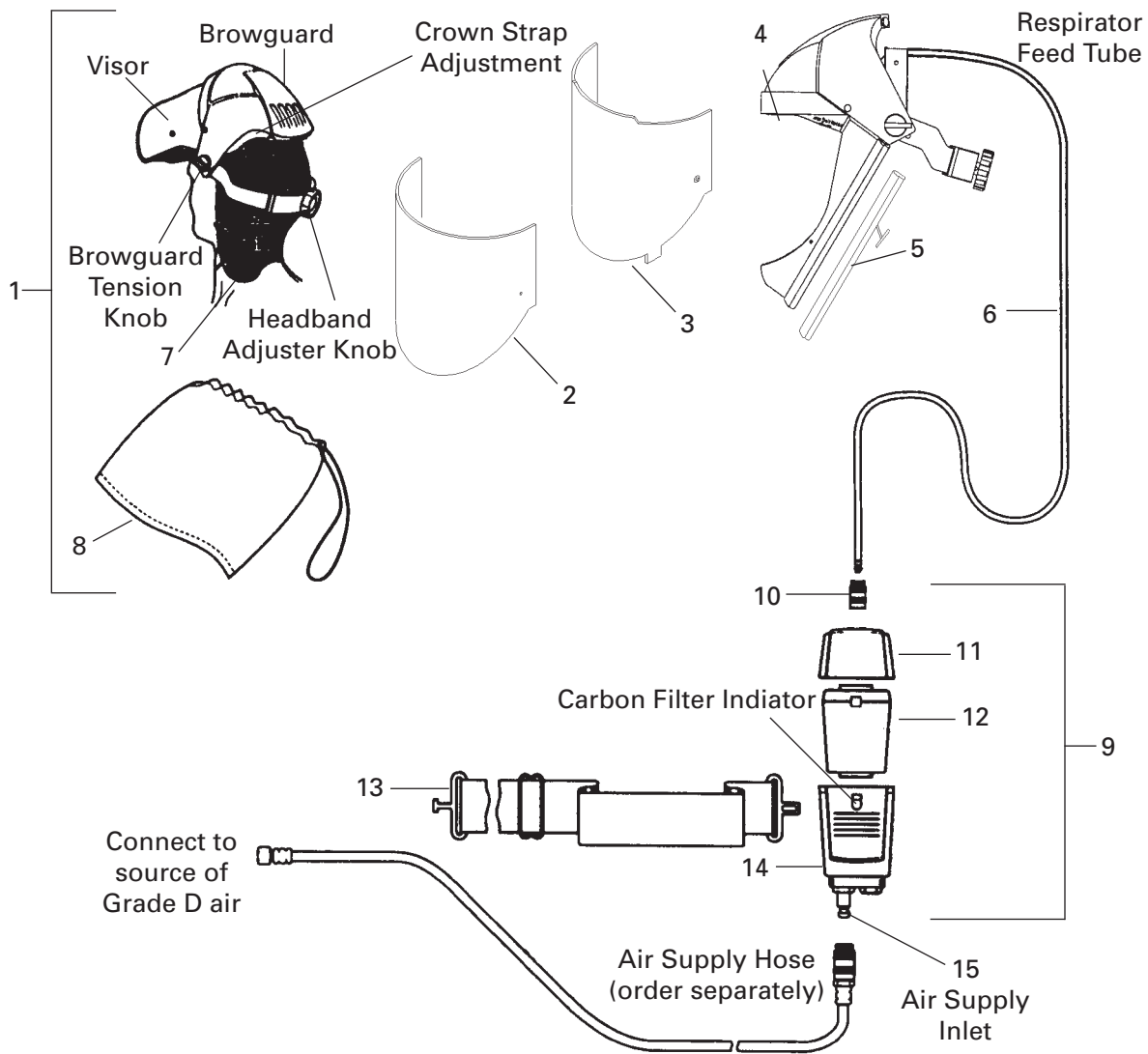

**165013 (MPV-625) PARTS LIST**

Ref. No.	Replacement Computer Part No.	DeVilbiss Part No.	Description	Individual Parts Required
1	165015	MPV-480	Visor Assembly (Includes Refs. 2-8)	1
2	165018	MPV-44-K10	Visor Cover (Kit of 10)	2
3	165035	MPV-490	Visor Window	1
4	165021	MPV-483	Browguard Assembly	1
5	165034	MPV-49	Fabric Face Seal	1
6	165001	MPV-457	Tube and Diffuser Assembly	1
7	165007	MPV-24	Hair and Neck Cover	1
8	---	---	Storage Bag	1
9	160014	MPV-469	Waist Belt/Filter Assembly (Includes Ref. Nos. 10-15)	1
10	165036	MPV-442	Miniature Quick Release Socket	1
11	160017	MPV-472	Regulator and Housing	1
12	160029	MPV-22	Disposable Carbon Filter	1
13	165041	MPV-4005	Waistbelt without Regulator	1
14	---	---	Waistbelt and Filter Housing	1
15	165032	MPV-10	Air Inlet Quick Disconnect Stem	1
16	160015	MPV-530	30 ft. Breathable Air Hose Assembly (Not Shown)	1
17	160016	MPV-550	50 ft. Breathable Air Hose Assembly (Not Shown)	1

### PART NUMBER CONVERSION CHART

Computer	No. Part No.	Description
160015	MPV-530	Breathable Air Hose (30 ft.) (5/16" Red Hose)
160016	MPV-550	Breathable Air Hose (50 ft.) (5/16" Red Hose)
165007	MPV-24	Hair and Neck Cover
165013	MPV-625	Air Supplied Respirator
160014	MPV-469	Waist Belt Assembly
165015	MPV-480	Visor Assembly
165018	MPV-44-K10	Visor Covers (Kit of 10)
165034	MPV-49	Replacement Fabric Seal
165001	MPV-457	Tube and Diffuser Assembly
165021	MPV-483	Browguard with Headgear
160029	MPV-22	Carbon Filter
165032	MPV-10	Air Inlet Quick Disconnect Stem
165035	MPV-490	Visor Window



DeVilbiss  
1724 Indian Wood Circle  
Maumee, Ohio 43537  
1-419-891-8200



**TYPE C SUPPLIED AIR RESPIRATOR IS  
APPROVED ONLY IN THE FOLLOWING CONFIGURATIONS:**

RESPIRATOR COMPONENTS										
TC#	Protection <sup>1</sup>	Airvisor MPV-480	Waistbelt and Regulator MPV-469	Alternate Air Supply Hose				Accessories		Cautions and Limitations <sup>2</sup>
				MPV-484-30	MPV-484-50	MPV-530	MPV-550	Lens Cover MPV-44-K10	Neck Cover MPV-24	
19C-0365	SA/CF	X	X	X	X	X	X	X	X	B,C,D,E,J,M,N,O,S

<sup>1</sup> Protection = SA Supplied Air CF = Continuous Flow

<sup>2</sup> Cautions and Limitations

- B. Not for use in atmospheres immediately dangerous to life or health.
- C. Do not exceed maximum use concentration established by regulatory standards.
- D. Air-line respirators can be used only when the respirators are supplied with respirable air meeting the requirements of CGA G-7.1 Grade D or higher quality.
- E. Use only the pressure ranges and hose lengths specified in the user's instructions.
- J. Failure to properly use and maintain this product could result in injury or death.
- M. All approved respirators shall be selected, fitted, used and maintained in accordance with MSHA, OSHA, and other applicable regulations.
- N. Never substitute, modify, add or omit parts. Use only exact replacement parts in the configuration as specified by the manufacturer.
- O. Refer to users instructions, and/or maintenance manuals for information on use and maintenance of these respirators.
- S. Special or critical User's Instructions and/or specific use limitations apply. Refer to User's Instructions before donning.

**WARRANTY**

This product is covered by DeVilbiss' 1 Year Limited Warranty.

---

**DeVilbiss Sales and Service: [www.devilbiss.com](http://www.devilbiss.com)**

---

**DeVilbiss**

DeVilbiss has authorized distributors throughout the world. For technical assistance or the distributor nearest you, see listing below.

**U.S.A./Canada Customer Service Office:**

195 Internationale Blvd., Glendale Heights, IL 60139  
Toll-Free Telephone: 1-800-992-4657 (U.S.A. and Canada only)  
Toll-Free Fax: 1-888-246-5732

**DeVilbiss Automotive Refinishing**

DeVilbiss has authorized distributors throughout the world. For equipment, parts and service, check the Yellow Pages under "Automotive Body Shop Equipment and Supplies." For technical assistance, see listing below.

**U.S.A./Canada Customer Service Office:**

11360 S. Airfield Road, Swanton, OH 43558  
Toll-Free Telephone: 1-800-445-3988 (U.S.A. and Canada only)  
Toll-Free Fax: 1-800-445-6643

