

DAD-500 (130026) DESICCANT AIR DRYING SYSTEM

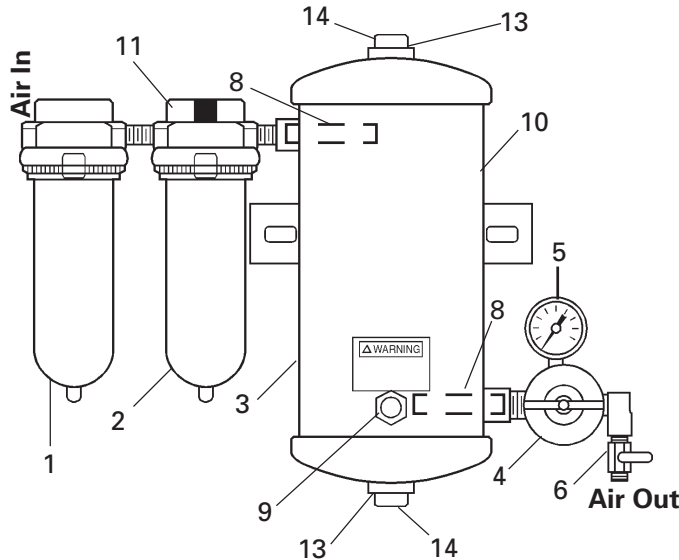

Figure 1
DAD-500 25 CFM Desiccant Air Dryer

PARTS LIST

Ref. No.	Replacement Part No.	Description	Individual Parts Req.
1	13-0041 (HAF-502)	Water Separator Filter	1
2	HAF-505	Oil Coalescing Filter	1
3	---	Desiccant Dryer	1
4	HAR-507	Air Regulator	1
5	GA-288	Gauge	1
6	VA-542	Ball Valve	1
*7	DAD-1	Replacement Desiccant (Not Shown) (1 Humidity Indicator Paper Included)	1
8	DAD-8	Air Filter, (inside of tank)	2
9	DAD-400	Humidity Indicator (1 Humidity Indicator Paper Included)	1
10	PT-417	Desiccant Tank (without desiccant) (Includes Ref. No. 8)	1
11	HAF-404	Filter Change Indicator	1
12	DAD-600	Desiccant Tune-Up Kit (Not shown) Includes 1 each: DAD-1, DAD-3, and HAF-6.	1
13	SSG-8217-K2	O-Ring Kit (2)	1
14	PT-96	Pipe Plug, Special, 1-1/2 NPT	2
15	VA-595	Main Air Supply Shut Off Valve (Not Shown)	1

*The Material Safety Data Sheet (MSDS) is available upon request.

DESCRIPTION

The 25 CFM DAD-500 Desiccant Air Drying System is designed to be a point of use system. It is capable of removing dirt, water, oil and water vapor from compressed air. It consists of a filter separator, coalescing filter, desiccant dryer, air regulator and main air supply shut off valve.

SPECIFICATIONS

13-0041 (HAF-502) Water Separator Filter - See page 3:

Air Inlet	1/2" NPT(F)
Air Outlet	1/2" NPT(F)
Air Flow Capacity	100 CFM
Maximum Operating Pressure	150 PSIG (10.3 Bar)
Maximum Temperature	150° F (65.6°C)
Automatic Drain	Standard
Filter	5 micron

HAF-505 Oil Coalescing Filter - See page 4:

Air Inlet	1/2" NPT(F)
Air Outlet	1/2" NPT(F)
Air Flow Capacity	55 CFM
Maximum Operating Pressure	150 PSIG (10.3 Bar)
Maximum Temperature	150° F (65.6°C)
Automatic Mechanical Drain	Standard
Pressure Differential Indicator	Standard
Filter	0.01 Micron

Desiccant Dryer - See page 2:

Air Inlet	1/2" NPT(F)
Air Outlet	1/2" NPT(F)
Air Flow Capacity	25 CFM
Maximum Operating Pressure	150 PSIG (10.3 Bar)
Maximum Temperature	150° F (65.6°C)
Humidity Indicator	Standard
Water Vapor Removal	-40° F Dew Point

HAR-507 Air Regulator - See page 4:

Air Inlet	3/8" NPT(F)
Air Outlet	1/4" NPT(F) (3 ea.)
Air Flow	60 CFM
Maximum Operating Pressure	150 PSIG (10.3 Bar)
Maximum Temperature	120° F (65.6°C)

VA-595 Main Air Supply Shut Off Valve - Not Shown:

Air Inlet and Air Outlet	1/2" NPT(M)
Maximum Operating Pressure	175 PSIG (12.0 Bar)

Shipping Weight: DAD-500 = 35 lbs.



**Risk of personal injury.
Risk of property damage.**

Except as otherwise specified by the manufacturer, this product is specifically designed for compressed air service and use with any other fluid (liquid or gas) is a misapplication. For example, use with or injection of certain hazardous gases in the system (such as oxygen or liquid petroleum gas) could be harmful to the unit or result in a combustible condition that may cause fire or explosion. Manufacturer's warranties are void in the event of misapplication and manufacturer assumes no responsibility for any resulting loss.

INSTALLATION



Risk of injury. Release all air pressure from system before servicing system. Be sure to read and understand all Service Bulletins on the separate components before using the system. Use only specified DeVilbiss parts.



Certain solvents, paints and chemicals may attack plastic filter bowl and can cause bowl failure. Do not use near these materials.

NOTE

Risk of equipment damage! Do not install your DAD unit where it is subjected to sudden depressurization cycles exceeding 20 PSIG. Quick relieving air solenoid valves, typical in some spray booths, will eventually fail pressure gauges and filters, and produce desiccant "dusting".

To minimize sudden depressurization effect, replace the existing solenoid with a "slow closing solenoid valve". (One source: Automatic Switch Co.) Or, install an air adjusting valve at the existing solenoids outlet.

1. **See Plumbing Guide on page 6.** Be sure to read all "Warnings" and "Cautions" in this manual and component manuals on the unit before installation or using this equipment.
2. Install air drying system as close as possible to the point where the air is being used. Use template to position location of system.

3. Install main air supply shut off valve and piping union fitting (supplied by user) upstream of air drying system to allow maintenance to the unit.
4. Install unit with air flow through filter in direction of arrow on top of filters.
5. Minimum 1/2" NPT piping is recommended. Avoid using fittings, couplings, etc. that restrict air flow.
6. Maximum inlet pressure and operating temperature is: 150 PSIG (10.3 bar) and a150° F (65.6°C)
7. Fill tank with desiccant materials (see paragraphs 4, 5, 6 under "MAINTENANCE").
8. Two 6' lengths of vinyl tubing are shipped loose with the system. Slide over automatic drains which protrude from bottom of the water/separator and the oil coalescing filters. Place the other end of vinyl tubing into appropriate receptacle. Prevent vinyl tubing from becoming kinked which would prevent free movement of liquids discharged from the automatic drain.
9. An optional manual drain (HAF-11) can be installed in place of the automatic drains.

OPERATION

After the system is installed and ready to use:

1. Attach air hose(s) to outlet valve.
2. Open main shut-off valve upstream of system.
3. Adjust regulator to desired setting by turning "T" handle in or out.
4. Open ball valve to supply air to spray guns or tool being used. With air flowing, readjust air pressure at regulator if necessary.
5. After use, shut off ball valve and bleed off residual air in hose.

MAINTENANCE



Risk of injury. Components under pressure. Relieve air pressure before performing any maintenance.



Certain solvents, paints and chemicals may attack plastic bowl and can cause bowl failure. Do not use near these materials. When bowl becomes dirty, wipe only with a clean, dry cloth. Immediately replace any crazed, cracked, damaged or deteriorated plastic bowl with a new plastic bowl. Reinstall metal bowl guard.



Risk of injury. Do not place unit in service without metal bowl guard installed.

1. Check system at least once per shift to insure proper drainage. Look for water in the drain tubing.

2. Before performing maintenance on system, close main shut-off valve located upstream. Bleed off residual air in system.

MAINTENANCE - DESICCANT DAD-1

NOTE

The desiccant tank contains an internal filter (DAD-8) at the inlet and outlet. Be careful not to damage them when changing desiccant.

1. **Replace the desiccant when the humidity indicator changes to a pink or white color.** Remove the pipe plug at the bottom of the tank. Allow the material to drain into a two (2) gallon or larger container.
2. Once all the material has been removed, replace the pipe plug (see "Note" following) and tighten (do not over tighten) securely (air tight).

NOTE

Use PTFE tape on pipe plug threads and all threaded fittings to facilitate removal in the future. Do not use loctite or any material that may bond and make removal difficult.



Risk of injury. Only use a socket wrench to remove the DAD-400 humidity indicator from the desiccant tank. Immediately replace the DAD-400 humidity indicator if damaged.

3. Replace the humidity indicator paper (supplied with DAD-1 Desiccant) by removing the DAD-400 humidity indicator. Pry out the old paper and push in the new paper (printed side facing away from the glass).
4. Remove the pipe plug on top of the unit.
5. Replace desiccant material, DAD-1 (19-0831). Two bags are supplied. Hold bag pointed upward and cut bag on dotted line. Grasp and hold bag where cut and rotate over opening on top of tank. Empty both bags into tank. ("Note" tank must be filled completely to prevent damage to desiccant.)
6. Wrap pipe plug with 2 wraps of PTFE tape. Replace the pipe plug and tighten until air tight (do not over tighten).
7. The humidity indicator will return to a blue color within five minutes.
8. The desiccant material should be disposed of properly.
9. Refer to the appropriate service bulletin for checking the filters and components.

NOTE

A desiccant Tune-Up Kit Part No. DAD-600, is available. Contains the following parts to completely recondition a desiccant air station:

Part No.	Description	Qty. Supplied
DAD-1	Desiccant	1
HAF-6	Water Separator Filter Element and O-Ring	1

Figure 2 13-0041 (HAF-502) 100 CFM Water Separator Filter

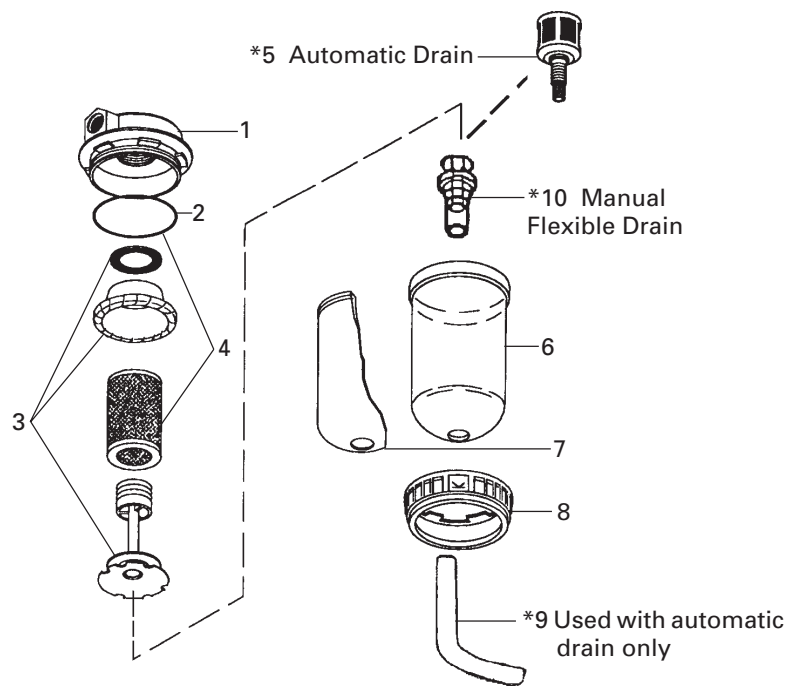

DAD-8 In-Tank Filters Replacement Instructions (for filter between the coalescing filter (stage 2) and the desiccant tank air inlet (stage 3)). These filters keep the desiccant within the tank: Replacing the air filter is not normally needed. It is required only when the filter has been damaged or plugged because the unit was not properly maintained.

- Be sure air supply to unit is shut off and bleed off all air pressure from the DAD unit.
- Make sure the desiccant material is drained from unit per above instructions.
- Remove the air supply line from the water separator inlet (first stage).
- Remove the filter bowls and filter elements from both the first and second stage filters of the unit.
- Use an open end 7/8" wrench and remove the hex nipple between the DAD tank and the coalescing filter. The nipple should unscrew out of the tank.
- Using a large #3 Phillips screwdriver, unscrew the filter.
- Use a large #3 Phillips screwdriver and reverse the above procedures to install a new DAD-8 filter. Install about halfway into the tank fitting.
- Reverse procedure to reassemble. Refill with desiccant.

DAD-8 In-Tank Filter Replacement Instructions (for the filter between the air regulator and the desiccant tank).

- Be sure air supply to unit is off and bleed all air from the DAD unit.
- Be sure all desiccant material is drained from the unit.
- Remove air regulator from tank by placing a 7/8" wrench on tank bushing and a 1-1/8" wrench on regulator.
- Remove the brass bushing from the tank using a 7/8" wrench. Using a large #3 Phillips screwdriver, unscrew the filter.
- Use a large #3 Phillips screwdriver and reverse the above procedures to install a new DAD-8. Install about halfway into the tank fitting.

NOTE

The air regulator can be installed back on the tank or additional piping can be installed to pipe the air to a different location. Remember that the volume of air flow can be affected by the pipe and distance to the new location. All fittings are regular pipe fittings.

- Reverse procedure to reassemble. Refill with desiccant.
- Before placing unit back into service, make sure plastic bowl and metal bowl guard are properly installed and securely locked in place.
- Confirm automatic drain operates properly after unit is in operation. Replace if necessary.

PARTS LIST 13-0041

Ref. No.	Part No.	Replacement Description	Ind. Parts Req.
1	---	Cover	1
2	---	O-Ring	1
3	HAF-26	Baffle Kit	1
4	HAF-6	Filter and O-Ring Kit	1
*5	HAF-18	Automatic Drain	1
6	HAF-8	Plastic Bowl	1
7	HAF-19	Metal Bowl Guard	1
8	HAF-409	Clamp Ring	1
*9	---	1/2 x 3/8 Vinyl Tubing 6 ft.	1
*10	HAF-11	Manual Drain	1

*DAD-500 is supplied with an automatic drain. If a 13-0041 (HAF-502) filter is ordered separately, it will include a manual drain (automatic drain must be ordered separately if desired).

DESCRIPTION

This 100 CFM water separator (Model 13-0041) (HAF-502) is designed to remove dirt, pipe scale and most liquid aerosol. It includes a 5 micron filter element.

MAINTENANCE 13-0041 (HAF-502) WATER SEPARATOR and HAF-505 OIL COALESCING FILTER

- Check for water in discharge tube and bowl at least once per shift to insure proper drainage.
- Before performing maintenance on unit, close main shut-off valve located upstream of filter. Bleed off residual air in unit.

- To open filter, press button located on clamp ring and rotate ring either clockwise or counterclockwise while pulling down on ring. The metal bowl guard and plastic bowl can then be removed from the filter head.
- Remove the water separator filter element (HAF-6) by loosening the baffle counterclockwise. Clean or replace the filter element. The element can be cleaned by blowing off with a duster gun (clean from inside out). Frequency of element cleaning/replacement will depend upon air quality, air usage and condition of the air piping. It is recommended to check and clean/replace the filter element every 3-6 months.
- Remove the coalescing element (HAF-28) by loosening counterclockwise. Change the element when the filter change indicator turns red or every 12 to 18 months of service.
- Inspect o-ring (2) for damage. Replace if necessary.
- Inspect plastic bowl for signs of damage such as cracks, crazing or deterioration. Replace if necessary. See "Caution" on page 2.



- Risk of injury. Do not place unit in service without metal bowl guard installed.**
- Before placing unit back into service, make sure plastic bowl and metal bowl guard are properly installed and securely locked in place.
 - Confirm automatic drain operates properly after unit is in operation. Replace if necessary.

Figure 3 HAF-505 55 CFM Oil Coalescing Filter

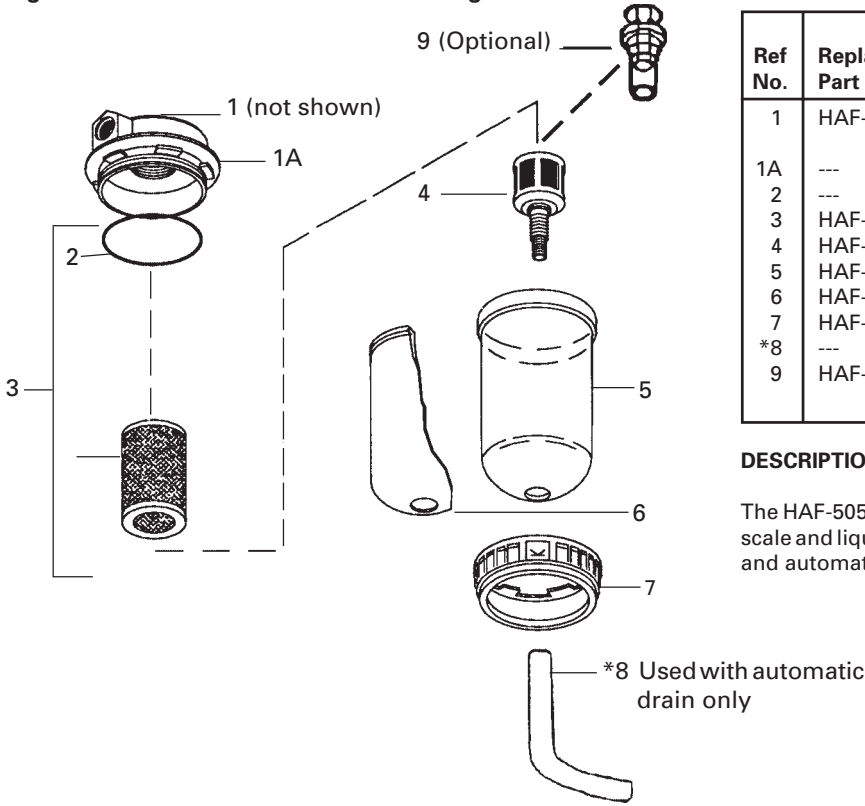

PARTS LIST HAF-505

Ref No.	Replacement Part No.	Description	Ind. Parts Req.
1	HAF-404	Filter Change Indicator (not shown)	1
1A	---	Cover	1
2	---	O-Ring	1
3	HAF-28	Filter and O-Ring Kit	1
4	HAF-18	Automatic Drain	1
5	HAF-8	Plastic Bowl	1
6	HAF-19	Metal Bowl Guard	1
7	HAF-409	Clamp Ring	1
*8	---	1/2 x 3/8 Vinyl Tubing 6'	1
9	HAF-11	Manual Drain (available separately)	1

DESCRIPTION

The HAF-505, 55 CFM filter is designed to remove oil, dirt, pipe scale and liquid aerosol. It includes a 0.01 micron filter element and automatic mechanical drain.

HAR-507 Regulator

DESCRIPTION

This regulator has been designed to receive air at main line pressure and to deliver it at a desired lower regulated pressure.

See **WARNINGS** on Page 2.

REGULATOR MAINTENANCE

1. Occasionally remove bottom plug (7) and clean valve seat (11) and body. Clean parts with denatured alcohol, wipe off seat and blow out body with compressed air.
2. To disassemble regulator, remove screws, bonnet, spring and spring button. Diaphragm assembly can now be removed.
3. Check all o-rings for signs of damage. Replace if necessary.
4. Reassemble parts. Center stem of valve in hole of regulator body. Screw bottom plug into body.

NOTE

Erratic operation or loss of regulation is usually due to dirt in the valve area and cleaning is necessary. If cleaning does not correct the problem, replace the items included in Repair Kit KK-4977. If unit leaks air at [A], install Repair Kit KK-4977.

PARTS LIST - Model HAR-507 Regulator Assembly

Ref No.	Replacement Part No.	Description	Ind. Parts Req.
1	---	#10-32 x 9/16 Fillister Hd. Screw	6
2	HAR-14	Cover	1
3	---	Spring Button	1
4	---	Diaphragm Spring	1
5	---	Body	1
6	---	Pipe Plug 1/4" NPT(M)	1
7	---	Bottom Plug	1
8	KK-4977	Repair Kit (includes Items 9 thru 14)	1
9	---	Diaphragm Assembly	1
10	---	O-Ring	1
11	---	Valve	1
12	---	O-Ring	1
13	---	Spring	1
14	---	O-Ring	1

Figure 4 HAR-507 Air Regulator

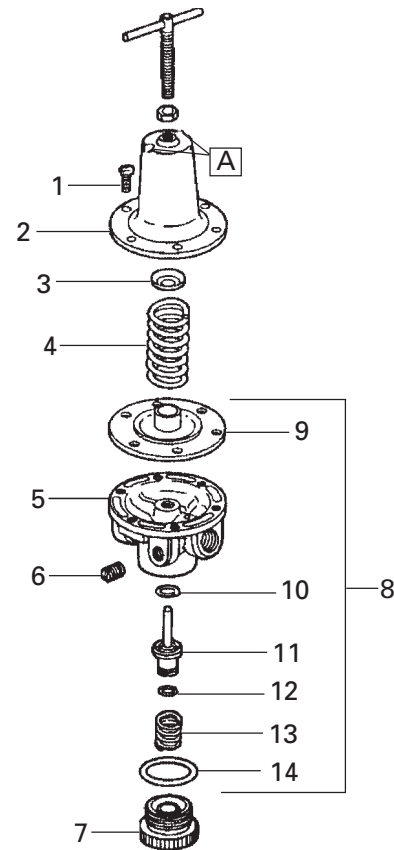

HAF18 Automatic Drain

NOTE

The automatic drain includes a float. If water gets into the float, the automatic drain may not function properly. Under normal conditions, water will not enter the float. However, water can get in the float if the filter bowl is washed with the drain installed or if air line contamination causes the drain mechanism to stick.

You can confirm the automatic drain is not operating if the water level in the plastic bowl is higher than the top of the automatic drain.

To remove water from the float, follow these instructions. Be careful not to lose or damage any internal parts of the automatic drain (replacement parts are not available - complete drain replacement will be necessary).

1. Remove automatic drain from plastic bowl by loosening plastic retaining nut. Keep retaining nut and o-ring for reassembly later.
2. Using a knife edge, carefully pry apart the float cover and bottom piece (See Figure 5).

Pry apart with knife edge.

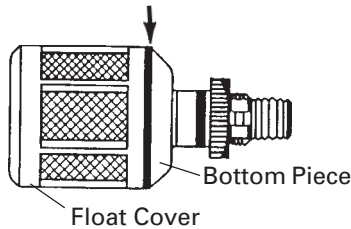

Figure 5

Float Guide

Be sure to reassemble all parts as shown into the float guide. Snap float guide cover into bottom piece.

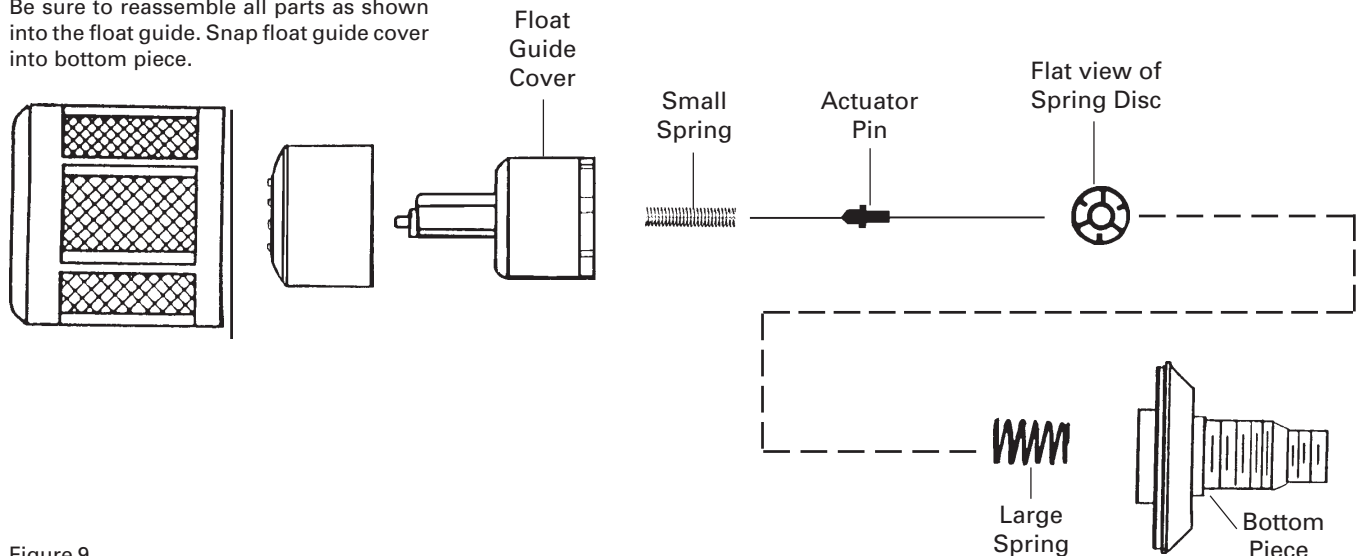

Figure 9

3. Slide float off float guide (See Figure 6).

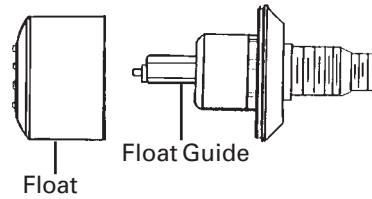

Figure 6

4. Using a knife edge, carefully pry off float cap (See Figure 7).

Pry apart with knife edge.

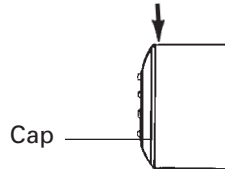

Figure 7

5. Clean inside of float. Remove all traces of water or dirt.
6. Insure rubber seal is in place in the center of the float stem (See Figure 8). If the seal comes out, press it back in place in the recess of the stem.

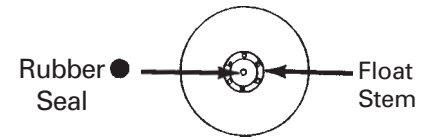

Figure 8

7. Replace the float cap (again, be certain the rubber seal, Figure 8, is in place).
8. Slide float over float guide.
9. Snap float cover onto bottom piece.
10. Install automatic drain into bowl. Be sure o-ring is in place (between the drain and bowl). Tighten the plastic retaining nut firmly by hand.
11. Monitor the automatic drain for proper operation. If it fails to operate properly, replace with a new unit.

NOTE

If the Float Guide inadvertently came apart, refer to Figure 9 and instructions.

A Properly Piped Shop Of Prime Importance for a Premium Finish.

The bottom line in finishing is a quality paint job. Though on the surface it may not seem a significant factor in your being able to turn out a quality paint job, the plumbing of your shop air lines is very important. Correct installation is necessary for the proper performance of your equipment - for an uncontaminated air supply and for sufficient pressure to your spray gun.

Correct airline piping is so important that this one factor alone can reduce contaminants in your air supply up to 75%*. Reducing contaminants to the filter also reduces the frequency of filter replacement, maintenance, and of course, reduces the risk of contaminants to the paint supply.

Even the size of the pipe is critical. Did you ever have only 60 or 70 pounds of pressure at your spray gun when your compressor should deliver 100 pounds? Using pipe that is too small in diameter can cause this pressure drop.

For example, if an air compressor delivers 100 psi through a 100 ft. pipe, 1/2" in diameter, there's greater pressure drop than if a 3/4" diameter pipe were used.

The following chart will help reduce pipe pressure drop.

Minimum Pipe Size Recommendations

Compressor Size	Compressor Capacity	Main Air Line	Min. Pipe Diameter
1-1/2 and 2 HP	6 to 9 CFM	Over 50 ft.	3/4"
3 and 5 HP	12 to 20 CFM Over 200 ft.	Up to 200 ft. 1"	3/4"
5 to 10 HP	20 to 40 CFM 100 to 200 ft. Over 200 ft.	Up to 100 ft. 1" 1-1/4"	3/4"
10 to 15 HP	40 to 60 CFM 100 to 200 ft. Over 200 ft.	Up to 100 ft. 1-1/4" 1-1/2"	1"

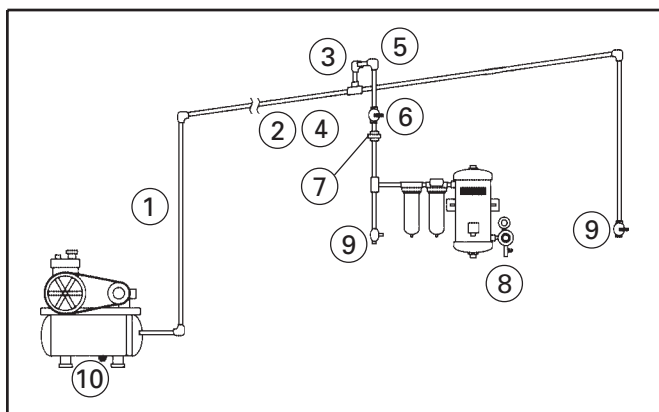

Body Shop Air Line Plumbing Guide:

- ① After leaving the air compressor, air line pipe goes straight up the shop wall as high as possible. This helps prevent any water from leaving the compressor and traveling through the pipe.
- ② Horizontal pipes should slope back towards the compressor at least 4" per 50 ft. As warm air leaves the compressor, it cools and thereby condenses as it travels through the pipe. This water vapor, a problem in itself, also can cause scaling and rust inside the piping. The backward sloping of the pipe helps push these contaminants toward the compressor drain.
- ③ Take-off comes from the top of the main air supply line at each air drop. This reduces the risk of water and other contaminants from traveling down the drop into the water separator.
- ④ Pipe diameter must be of sufficient size for the volume of air being passed as well as the length of pipe used. This will minimize pressure drop.
- ⑤ First air drop should be at least 25 ft. from the compressor although 50 ft. is optimum. This allows the compressed air to cool to room temperature so any condensation can occur before it gets to the water separator.
- ⑥ Shut-off valve is installed before the point of use filter. This allows air to be shut off for filter maintenance.
- ⑦ Pipe union installed before DAD-500 allows easy installation and removal of the air drying system.
- ⑧ Point-of use filter (not shown) attaches to spray gun, order HAF-507. Strongly recommended for eliminating any remaining contaminants.
- ⑨ Drain Valves - The daily draining of the system at each outlet disposes of the contaminants that build up in the air supply.
- ⑩ Drain the compressor trap daily if equipped with a manual drain.

Proper maintenance of the air compressor can reduce airborne contaminants such as particules and oils, and reduce heat and loperating cost. Check air filters, oil level and perform regular maintenance per operators manuals.

Guidelines To Piping Your Shop

- Pipe slopes upward - recommend 4" rise in 50 ft.
- Minimum 25 ft. to first outlet (50 ft. optimum)
- Pipe size (see chart)
- Shut off valve before filter
- Drain daily

WARRANTY

This product is covered by DeVilbiss' 1 Year Limited Warranty.

DeVilbiss Worldwide Sales and Service Listing: www.devilbiss.com

Industrial Finishing

DeVilbiss has authorized distributors throughout the world. For technical assistance or the distributor nearest you, see listing below.

U.S./Canada Technical Service Office:

195 Internationale Blvd., Glendale Heights, IL 60139
Toll-Free Telephone: 1-888-992-4657 (U.S.A. and Canada only)
Toll-Free Fax: 1-800-368-8401

DeVilbiss Automotive Refinishing

DeVilbiss has authorized distributors throughout the world. For equipment, parts and service, check the Yellow Pages under "Automotive Body Shop Equipment and Supplies." For technical assistance, see listing below.

U.S./Canada Customer Service Office:

1724 Indian Wood Circle, Suite J-K, Maumee, OH 43537
Toll-Free Telephone: 1-800-445-3988 (U.S.A. and Canada only)
Toll-Free Fax: 1-800-445-6643

