

**KAESER**  
COMPRESSORS

*Built for a lifetime.™*



# Rotary Blowers and Packages

**BB - HB Series**

**DBS - FBS Series**

Flow Capacities to: 5650 cfm

Pressures up to 15 psig, vacuum to 15" Hg

**[kaeser.com](http://kaeser.com)**

# Built-for-a-lifetime™ Products

## A family tradition of quality

*Kaeser has been designing and manufacturing superior industrial machinery since 1919. With nearly a century of manufacturing experience, we pride ourselves on upholding our traditions of quality and craftsmanship. Our reputation for reliability, energy efficiency, and excellent service has helped us grow into a global leader in blower and compressed air technology.*

## Integrated engineering

Kaeser blower packages offer the best possible combination of quality construction, reliable performance, and ease of ownership. Our standard package design features a full scope of supply that is unmatched in the industry. A complete package design reduces time spent specifying and purchasing blower system components, and after the sale there is only one supplier to call for technical or other support on any part of the blower package.

## Low life cycle costs

In addition to reducing engineering and installation costs, our blowers are very energy efficient. They are also designed for easy maintenance, and the few maintenance points are all accessible through one cabinet panel. Of course, the rugged reliability of Kaeser blowers means fewer lifetime repairs. In fact, Kaeser is so confident in the benefits of our design that we offer an unbeatable warranty on our blower blocks sold as part of our standard packages.

## Easy installation

Our complete packages are designed with a unique component layout to minimize floor space and allow side-by-side placement. Kaeser's design combined with a full six-sided enclosure (standard), results in a blower package with the least noise and vibration. No additional soundproofing is needed. Further, all integrated models arrive pre-assembled, offering major time and labor savings during installation.

## Superior connectivity

Kaeser blowers feature the integrated Sigma Control 2™ to monitor and control the blower package. Versatile communication modules enable easy connection with master controllers, like Sigma Air Manager 4.0 (SAM) or other centralized control systems for enhanced reliability, energy optimization, and plant automation.

*Today, Kaeser employs over 5,500 people and our growing distribution network provides reliable and sustainable compressed air system solutions in 100 nations throughout the world.*



EBS 380M

SIGMA

**KAESER**

STC AA

SFC

# State-of-the-art manufacturing

*Kaeser blowers are manufactured in our extensive facility in Gera, Germany. State-of-the-art CNC lathes, milling machines, and grinding machines produce our high quality timing gears, proprietary rotors, housings, and other components to very precise tolerances.*

*Continuous research and development keep Kaeser products at the forefront of technology and give our blowers a reputation for efficient operation, easy maintenance, and unparalleled reliability. Highly skilled technicians assemble each unit according to our ISO 9001/14001 procedures. The finished products must meet strict quality standards and pass through a rigorous inspection and testing program before shipping to our customers and stocking centers around the world.*

## Gera Plant

Covering an area of almost 15 acres, our blower plant in Gera, Germany produces Kaeser's wide range of rotary blowers. This location features state-of-the-art technology for Kaeser's engineering, R&D, production, and testing facilities.



### Precision milling and grinding

Rotor profiles and critical components are precision machined and then finished on a CNC grinder.



### Continuous quality control

All critical components such as rotors and casings are measured and verified using the latest in 3D computer technology and coordinate measuring machines.



### Advanced machining centers

State-of-the-art machining centers in climate controlled rooms produce the blower components.



### **Environmentally friendly powder coating system**

Sound attenuating enclosure panels are given their super-fine finish by a powder coating process where epoxy finish is baked on at 350°F. The corrosion and scratch resistant finish meets the highest quality standards.



### **Meticulous blower assembly**

Highly trained specialists assemble each blower and complete package according to our strict ISO 9001 standards.



### **Comprehensive unit testing**

Each and every blower undergoes a run-test under maximum load conditions to verify mechanical integrity as well as a slip-test to verify performance. The test data is recorded in the machine documentation. Every package is shipped in set-up condition, fluid-filled, and ready for operation.

# How it works

## Kaeser rotary lobe blowers

The images depict cross sections of the flow chamber in Kaeser's rotary lobe blower block during the pressure build-up process.



### Oil-free, isochoric compression process

As the intake air passes through the rotary blower's flow chamber, its volume remains constant (isochoric). Actual compression takes place outside the blower block with the accumulation of the air mass taking place in the subsequent process. This "adaptive" compression always produces only the amount of pressure needed. This makes rotary blowers particularly suitable for applications with a relatively high proportion of idling (e.g. pneumatic conveying) and/or heavily fluctuating pressure.

The numbers correspond to the points in the below pressure-volume diagram.

1. Intake of atmospheric air (left rotor).
2. Air is conveyed towards the pressure side; compression begins at the 120° rotation angle due to prior influx of already compressed air.
3. Compression in the flow chamber ceases; discharge begins.
4. Conveyed air mass is discharged into the process.

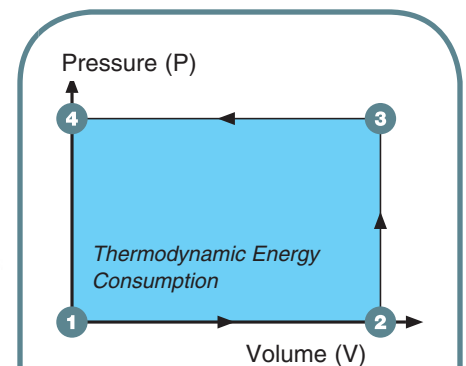

The pressure-volume diagram (P-V diagram) illustrates the energy, or compression work, expended for compression in the blue area between points 1 to 4.

# Kaeser screw blowers

Shown here is the pressure build-up process for Kaeser's screw blower block. The air volume is enclosed in the screw chamber.



## Oil-free isentropic compression process

As it is being conveyed through the screw compression block, the entropy of the intake air pressure remains virtually constant (isentropic). Compression takes place in the block, where the air volume is continually reduced until it reaches the discharge and is pushed out against the pressure. The lower compression effort required to achieve the same air volume results in lower energy consumption. Screw blowers are ideally suited for applications with a near constant pressure demand and which require long running periods, such as in filter bed aeration, flotation, etc.

The numbers correspond to the points in the below pressure-volume diagram.

1. Intake and capture of atmospheric air.
2. Conveying toward pressure side to outlet.
3. Pressure increase through volume reduction.
4. Compressed air discharged.

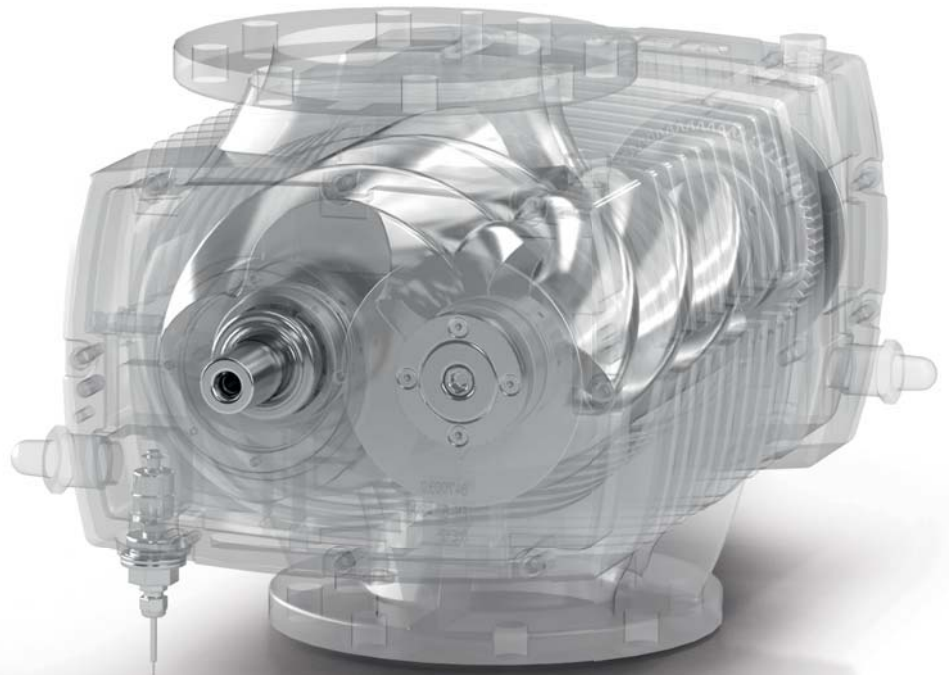
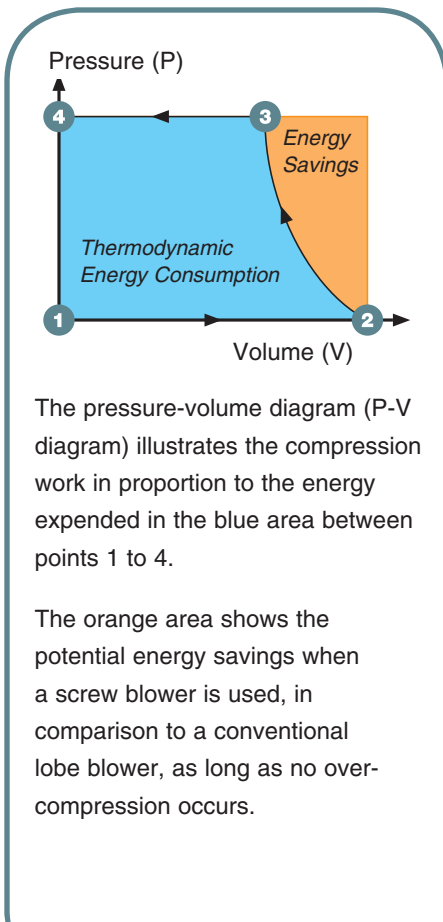



### **Superior Warranty Protection**

Kaeser blowers are backed by our 24-month warranty protection against defects in material and workmanship. The blowers in our Com-paK packages carry 5-year warranties.

Furthermore, Kaeser guarantees shipment of any standard part required for emergency breakdown repairs on any standard blower within one working day of order receipt, or the parts are free.



# Advanced blower design

## Rugged reliability

All Kaeser Omega lobe blowers share a durable design that includes rigid casings, cast bearing supports, and one-piece rotors. The substantial casing construction and proprietary port design ensure smooth, quiet operation at all speeds. The precision machined, case-hardened, spur-type timing gears and oversized cylindrical roller bearings provide years of reliable service. Piston-ring seals ensure optimum internal sealing and oil-free air.

## Versatility

Omega lobe blowers can be mounted horizontally or vertically to suit the specific application. They are also available as complete blower packages.



## One-piece rotors and sealing strips

One-piece, ductile iron rotors are balanced to the closest tolerances for smooth, efficient operation at all speeds and pressures. Our over-sized shaft diameters and rigid construction minimize shaft deflection. Specially designed rotor sealing strips reduce sensitivity to contamination and intermittent thermal overloading.

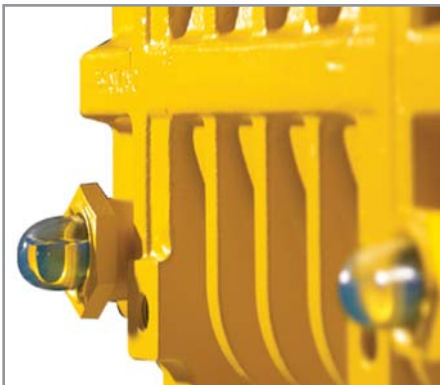

## Superior casing

The distinctive ribbed housing ensures strength, rigidity, and aids in proper cooling. Integral bearing supports and head plates are machined into the castings to provide better strength and to maintain alignment in the most demanding applications. Our unique port design ensures smooth, quiet operation at all speeds.



## Straight-cut gears

Spur-type, case-hardened, precision ground timing gears minimize vibration and mechanical noise and ensure optimal rotor timing for improved efficiency. The straight cut gears do not subject the rotors to axial loads, making it possible to use longer lasting roller bearings.



## Generously sized bearings

Heavy duty cylindrical bearings absorb the continuously changing radial gas-forces exerted onto the cylinders and last up to ten times longer than axial thrust bearings under the same load conditions.

Oil slingers on both gear and drive ends of the blower provide lubrication to the bearings, gears, and input shaft seal to ensure long service life.

# Complete blower packages

## Com-paK™



### Innovative cabinet design

Com-paK models are fully enclosed in powder coated and insulated steel cabinets. They all feature positive ventilation with dedicated fans to remove latent heat even when the main motor is off — making Kaeser blower packages more reliable in a wide range of climates and uses. The process air circuit is separate from the ventilating air for improved efficiency.



### High efficiency motors

Premium efficiency TEFC/IP-55 motors are conservatively sized to ensure reliable operation and overcome changes in system pressure.



### V-belt drive with guard

V-belt drive provides flexible pressure/flow combinations and dependable performance. Kaeser packages are standard with our automatic v-belt tensioner. Our fully-enclosed belt guard offers complete protection and is easily removed for convenient maintenance access.



### Inlet silencer with integral filter

Our silencers are designed for our blower noise frequencies. Absorptive material reduces pulsation noise and the reusable polyester filter protects the blower from harmful particulates and minimizes pressure drop.



### Instrumentation

Standard instrumentation includes pressure/vacuum gauges, discharge temperature gauge with shut-down switch, and inlet filter differential monitoring or vacuum filter switch.



### Pre-mounted valves

Check plate and relief valves are standard. Unloaded start valve is optional. All come pre-mounted to save on installation costs.



### Com-paK™ BBC - HBC Series

Omega lobe blowers are also available as Com-paK units, designed to minimize space requirements and reduce installation costs. The Com-paK is complete with a premium efficiency TEFC motor, silencers, and a gauge cluster. The package arrives ready for installation.

All routine maintenance points are accessible from the front while all utility connections are located in the back. All pipe connections and cooling air apertures are located at the rear of the unit, which makes side-by-side installation possible.

# Rotary screw blower packages

## DBS, EBS, and FBS series



### Blower block

Kaeser's advanced blower design offers the best combination of low vibration, energy efficiency, and low noise operation. The ribbed design of the single-piece casing body ensures optimal heat dissipation and torsional rigidity.



### Sigma Profile™

Our high-efficiency screw blower air ends feature the power-saving Sigma Profile™ design. They are precision machined and optimized in size and profile to ensure maximum air delivery while keeping power consumption to an absolute minimum. Superior specific power is maintained across a wide control range.



### Durable bearings

Four heavy-duty cylindrical roller bearings absorb the continuously changing radial forces and are rated to ensure long air end service life. The rollers are encased in oil resistant cages for optimum lubrication at all speeds.



### Dependable seals

The proven sliding ring seal on the blower aircend's drive shaft is maintenance-free and provides dependable sealing, even in hot, dusty environments.



### Continuous system monitoring

Oil level and temperature sensors are integrated into the blower aircend. The oil chamber is designed to ensure accurate readings even during machine operation when the oil is circulating.



### High efficiency motors

Premium efficiency TEFC/IP-55 motors are conservatively sized to ensure reliable operation and overcome changes in system operation.

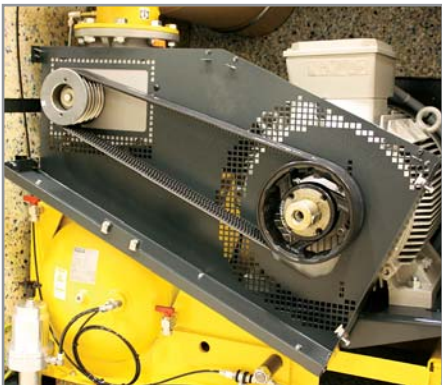

### V-belt drive with guard

V-belt drive provides flexible pressure/flow combinations and dependable performance. Drive efficiency is maintained by our automatic v-belt tensioner. Our fully-enclosed belt guard offers complete protection and is easily removed for convenient maintenance access.



### Inlet/Outlet silencers

Inlet and outlet silencers come standard. Washable and reusable polyester inlet filter protects the blower from damaging particulates. Filter media has low flow resistance to minimize pressure drop and the filter differential pressure is displayed on the Sigma Control 2.

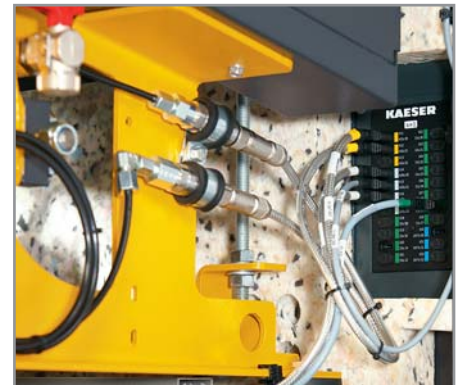

### Comprehensive sensor options

Options include a wide range of sensors and switches for monitoring pressure, temperature, speed, oil level, and filters to ensure dependable operation and enable remote monitoring of critical operating parameters.

# Package cooling and enclosure design

## Parallel cooling concept

Kaeser's integrated package design separates airflows for the blower, motor, and electrical cabinet. This ensures air is not preheated before entering the blower, which keeps the overall efficiency higher. It also ensures the coolest possible air is being channeled across the drive motor. A dedicated fan ensures that regardless of the operating speed of the package, cooling air is flowing through the enclosure.

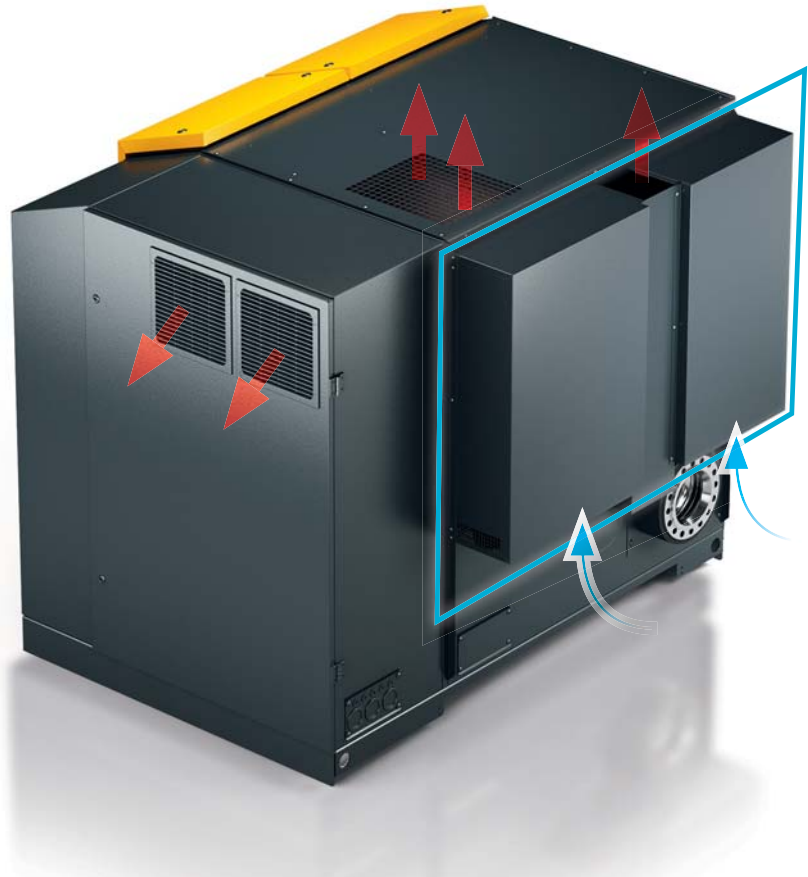

## Extremely low sound and vibration

All integrated packages feature a standard enclosure that is built for exceptional noise reduction and easy access to maintenance points. Heavy gauge construction and powder coat finish make it suitable for both indoor and outdoor installation. Heavy duty dampers absorb vibrations before they reach the base of the unit or sound enclosure. They also reduce stress on plumbing and wiring.



*Shown here is Kaeser's HBPi large frame blower package*

# Service-friendly design

*Kaeser has been a leader in creating fully packaged blowers that are reliable, durable, energy efficient, and simple to maintain. Our blower packages set the standard in the blower industry. In addition to a full scope of supply, these models feature an open package design to simplify routine maintenance. When you consider all the benefits of owning a Built for a lifetime™ machine, it's clear that a Kaeser integrated blower package will save you money, year after year.*



## Easy service features:

- A single front panel easily removes for complete access to all major components
- Inlet filter requires no tools for servicing
- Drain valves with gasketed caps simplify fluid changes
- High visibility sight glasses allow the fluid levels to be checked at a glance from the front of the package
- V-belt guard is easily removed, but provides full protection
- Automatic belt tensioner maintains drive efficiency and eliminates frequent adjustments. Tension status is easy to see at a glance and adjustments only take a few minutes.
- Easy-to-read instrumentation
- Easily accessible motor grease fitting



EB 380S



**KAESER**



STC ΔΔ

EB 380S



**KAESER**



STC ΔΔ

EB 380S



**KAESER**



SFC



# Integrated packages: STC, OFC, and SFC

## Superior efficiency options

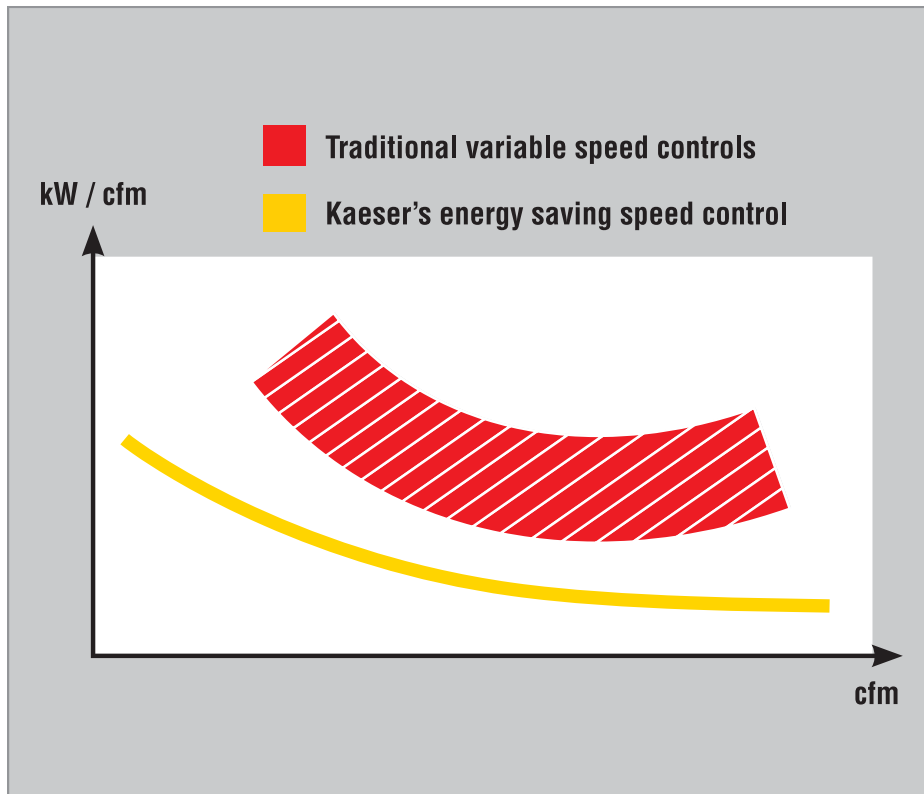

### Wide control range

Kaeser matches the blower block, drive motor, and variable speed controller for optimal performance, which provides better specific performance over a wider range of flows. This ensures maximum efficiency in multi-unit operation while always meeting fluctuating demand.

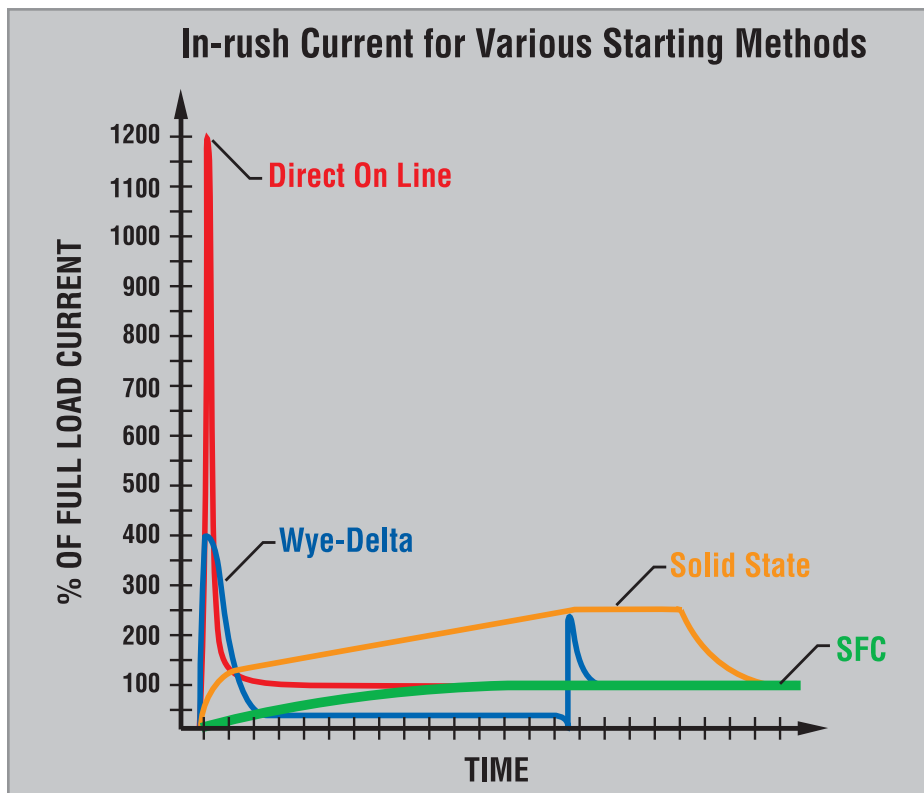

### Kaeser Start Control

Sigma Start Control (STC) provides reduced current starting (wye-delta) for fixed speed units. The package is also equipped with premium contactors, overload protection, and phase loss monitoring.

# Communications capabilities

## Intelligent control and protection with Sigma Control 2™



To protect your investment and ensure the most efficient operation possible, we control integrated blower packages with our Sigma Control 2™. This intelligent controller comes standard with multiple pre-programmed control profiles so you can select the one that best fits your application.

Sigma Control 2 monitors a wide range of operating parameters, shuts the unit down to prevent damage, and signals if immediate service is required. It also tracks preventive maintenance intervals and provides notice when PMs are due. An RFID sensor provides secure access and simplifies managing maintenance intervals.

An SD card slot with included SD card enables fast, easy software updates and offers long-term data storage for analyzing energy consumption and blower operation.

Sigma Control 2 has superior communications capabilities. An Ethernet port and built-in web-server enable remote viewing. ModBus, Profinet, Profibus, Devicenet, and other industrial communications interfaces are also available as plug in options for seamless integration into plant control/monitoring systems.

## Advanced energy management with Sigma Air Manager 4.0



Kaeser's Sigma Air Manager 4.0 (SAM) can control up to 16 blowers and only turns them on when needed to meet air demand. This improves system stability, reduces energy use, and equalizes blower run time.

SAM 4.0's advanced communications capabilities makes connecting with plant SCADA systems easier than ever. Using the desired system flow rate calculated by the SCADA, SAM 4.0 selects the most efficient combination of units to produce the required flow, keeping energy costs as low as possible.

SAM 4.0 also provides blower status messages and alarms to help minimize downtime. Using SAM 4.0's built-in Kaeser Connect capabilities, you can remotely monitor operating status, maintenance schedules, and energy usage—on any networked device.

With SAM 4.0's robust data storage hardware and analysis software you can record and review your system's function and energy usage in easy-to-read charts. This continuous system data acquisition helps you analyze plant operations and optimize energy efficiency.

# Blowers for special applications

*Kaeser offers a variety of blower designs for your special application. Consult factory for sizing and availability.*



## **Rotary vacuum pump (WVC Series) Flows to 2800 cfm and Ultimate vacuum (0.002 Torr)**

When producing fine vacuum in combination with a corresponding backing pump, the WVC significantly increases pump suction capacity and vacuum performance. The use of a frequency converter is particularly beneficial, as the converter enables simultaneous activation of rotary vacuum and backing pumps at atmospheric pressure, thereby significantly reducing pumping time.

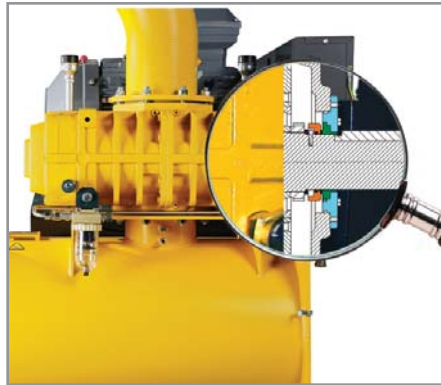

## **Gas tight blowers (N Series) Flows to 5500 cfm Pressures up to 15 psig**

For nitrogen and other gas conveying applications, Kaeser's Omega N series blower is available up to 5500 cfm. Our single-envelope design can be configured into special packages with an input shaft sliding-ring seal.



## **Steam blowers (B Series) Flows to 3780 lbs./hr.**

Kaeser's Omega B series blowers are specifically designed for compression of water vapor with vacuum operation in combination with water injection cooling. They feature Ni-Resist 3 casings, G-X8 CrNi stainless steel rotors, and Teflon® shaft seals with stainless steel shaft sleeves.

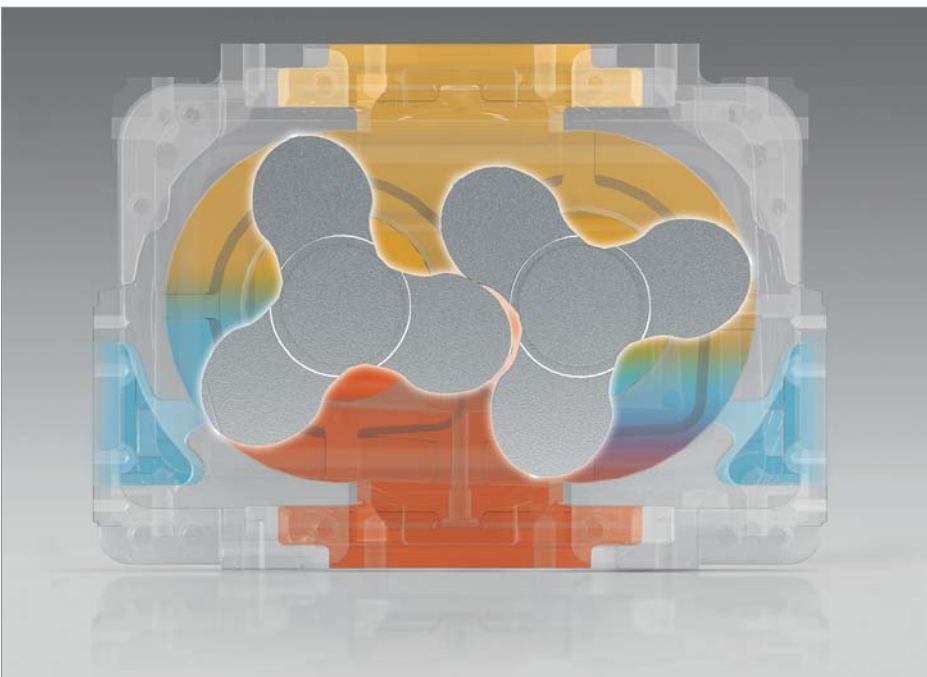

## **Vacuum blowers (PV Series) Flows to 4300 cfm at 27" Hg-V**

For use in vacuum ranges up to 27" Hg vacuum. Kaeser's PV blowers have a unique design with pre-inlet injection cooling that is resistant to contamination in the air stream.

### **How it works**

Low pressure air is trapped between the rotors and the casing at the inlet of the blower (yellow). As the rotors turn toward the discharge (red), ambient air enters through the pre-inlet cooling ports (blue). This air provides the cooling needed for continuous process vacuums to 27" Hg in a single stage with no need for contacting seals or liquid injection.



# The right blower for every application



## Performance overview

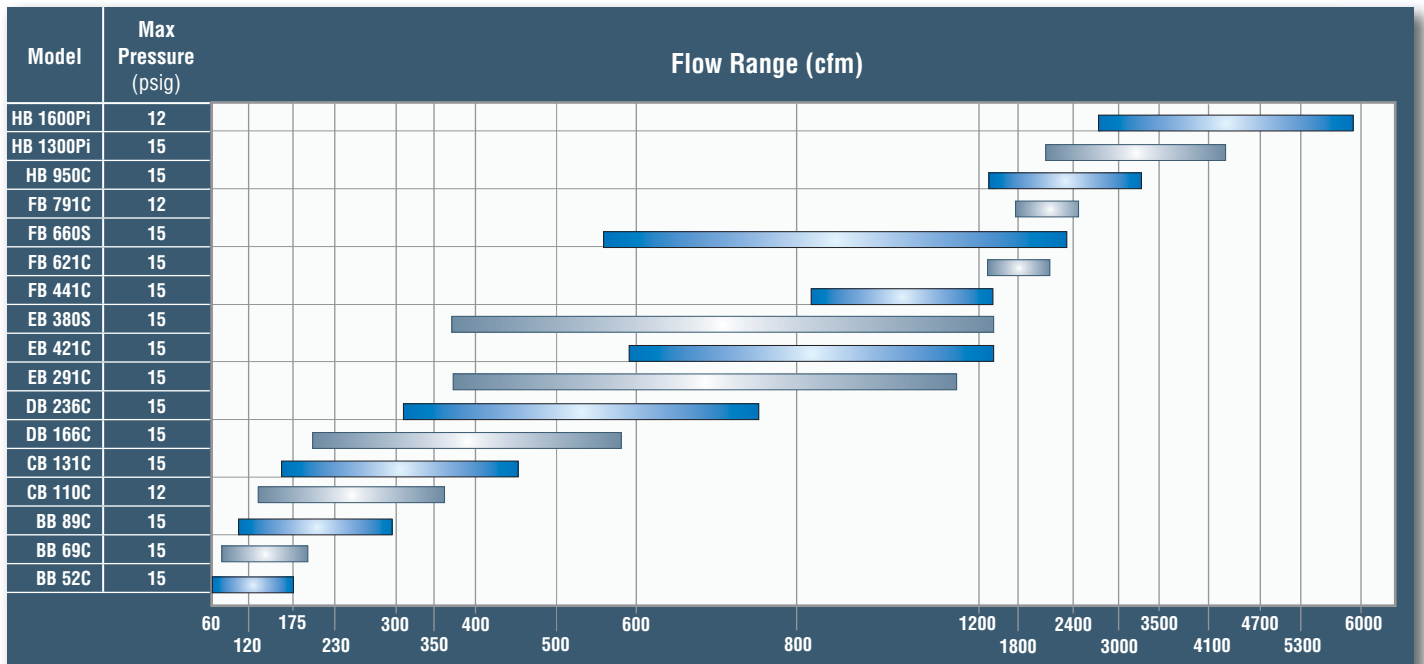

Maximum air delivery @ 4.35 psig in accordance to ISO 1217, Part 1, Annex C.

# Engineered solutions

Kaeser is always at your service to help design and optimize your air system. From complex installations to challenging environments to limited space, Kaeser can design a system to meet your specific requirements for performance and reliability.

## System design

Kaeser specializes in designing a complete air system that takes into account the numerous variables necessary to ensure optimal system performance. Based on your needs, our engineers can recommend the best layout, ventilation, and cooling fan capacity for your system.

To help make your project planning easier, Kaeser can also produce 2D and 3D drawings of the proposed system. Being able to visualize the new equipment and how it will fit into the building with the existing equipment is a huge asset in facilitating your installation planning.

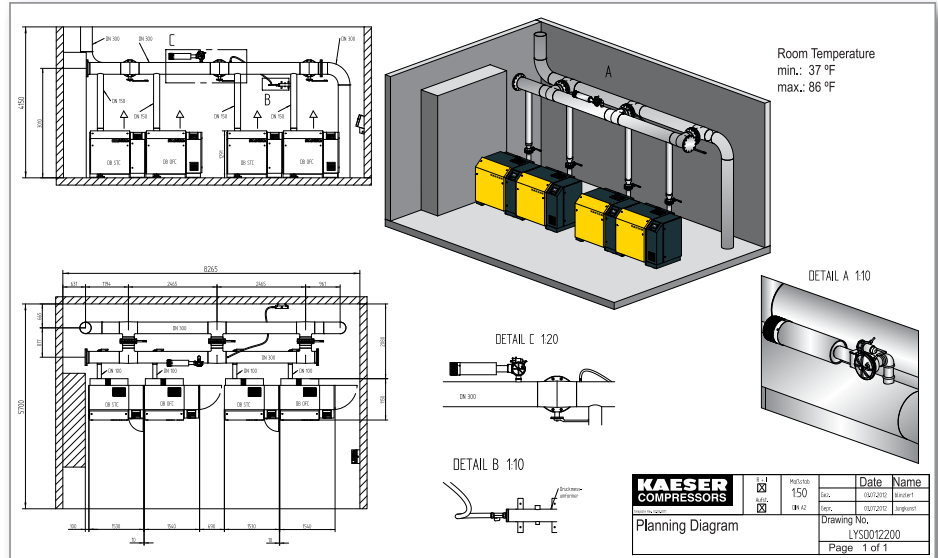

Kaeser can provide valuable system drawings to simplify your installation planning.

## Quick-ship series

### Available for immediate shipment

#### Need it now?

Kaeser stocks a full range of Com-pak blower packages from 5 to 75 hp. Most orders can be shipped within one working day.

Whether it's for a new installation or replacement unit, Kaeser has a solution ready for you or the parts are free.



# The world is our home

As one of the world's largest compressed air systems providers and compressor manufacturers, Kaeser Compressors is represented throughout the world by a comprehensive network of branches, subsidiary companies and factory trained partners.

With innovative products and services, Kaeser Compressors' experienced consultants and engineers help customers to enhance their competitive edge by working in close partnership to develop progressive system concepts that continuously push the boundaries of performance and compressed air efficiency. Every Kaeser customer benefits from the decades of knowledge and experience gained from hundreds of thousands of installations worldwide and over ten thousand formal compressed air system audits.

These advantages, coupled with Kaeser's worldwide service organization, ensure that our compressed air products and systems deliver superior performance with maximum uptime.



**KAESER  
COMPRESSORS**

*Built for a lifetime.™*

[www.kaeser.com](http://www.kaeser.com)

**Kaeser Compressors, Inc.**  
511 Sigma Drive  
Fredericksburg, VA 22408 USA  
Telephone: 540-898-5500  
Toll Free: 800-777-7873  
[info.usa@kaeser.com](mailto:info.usa@kaeser.com)

**Kaeser Compressors Canada Inc.**  
3760 La Vérendrye Street  
Boisbriand, QC J7H 1R5 CANADA  
Telephone: (450) 971-1414  
Toll free: (800) 477-1416  
[info.canada@kaeser.com](mailto:info.canada@kaeser.com)

**Kaeser Compresores de México  
S de RL de CV**  
Calle 2 #123  
Parque Industrial Jurídica  
76100 Querétaro, Qro.  
Telephone: 01 (442) 218 64 48  
[sales.mexico@kaeser.com](mailto:sales.mexico@kaeser.com)

**Kaeser Compresores de  
Guatemala y Cia. Ltda.**  
Calz. Atanasio Tzul 21-00, zona 12  
El Cortijo II, Bodega 501  
01012-Guatemala City  
Telephone: +502 2412-6000  
[info.guatemala@kaeser.com](mailto:info.guatemala@kaeser.com)